

2007 Technical Conference of the IA

Selection of Pressure Reducing Pilots for Low Volume Irrigation Systems

Amos Yardeni, M.Sc. Consultant Engineer
AY-TEC Consultants

Abstract

Hydraulic pilots are used for pressure regulation of hydraulic valves. Typically, a combination of normally- closed pressure-reducing pilot is used in low volume irrigation systems. This configuration is presented in the following study as an example.

As all irrigation devices, hydraulic pilots are made to conform to the industry requirements and quality standards. Yet, there is no standard for the hydraulic performance. The specs are set by makers, and obviously, the products are varied in some important features. Thus, selection of an appropriate pilot requires relevant data, especially for applications that include thin-walled pipes or brackish water supply,

Typical requirements are precision, repeatability, smoothing of pressure surges and high clogging resistance.

The study analyzes differences between 2-way and 3-way modes, regarding the in-field conditions.

Some quantitative hydraulic tests were devised and applied to define different pressure pilots. These tests include: flow characteristic, hysteresis, rebound, precision and repeatability. Consequently, we developed a methodical approach for selection or definition of hydraulic pilot.

Typical Conditions of Low-Volume Irrigation

Application of low-volume irrigation systems requires a typical set of specs. High precision and minimal headloss in a low working pressures in one hand. High resistance for clogging, corrosion, wear and outdoor conditions at low overall cost on the other hand. Hydraulic pilots are no exception to that.

High chemical resistance is critical because low volume irrigation combines fertigation, chlorination and acid flushing as routine practices. That means, that the devices materials should withstand low and high pH, high chlorine content and other chemical deteriorating agents.

Using reinforced plastics for hydraulic designs is a very good solution. Plastics feature low weight, low cost and robust material. Plastic materials withstand chemical and outdoor conditions.

In many cases low volume irrigation systems use brackish water. Consequently, the suspended solid content is relatively high. The suspended solids are widely variable in size and source. Soil particles as clay, silt and sand, are always found in water. Micro-fauna and micro-flora dead and alive are abundant and proliferating, looking for a chance to settle down. All this population is a constant risk of clogging water passages, small orifices or sharp corners. The flow of suspended solids continuously grinds passages and orifices. The design and materials should withstand that as well.

Last but not least are the cost considerations. Low volume irrigation systems are cost effective. New designs and material selection should comply with it. For example, needle valve is replaced with simple orifice; stainless steel screen is replaced with fixed plastic grid. These replacements are cost

Hydraulic Valves

By definition, hydraulic valves are operated by the water line pressure by means of membrane or piston. There are many designs of hydraulic valves in irrigation applications. The valves designs are different from each other by construction, hydraulic characteristics, materials, endurance and cost. According to the requirements of low volume irrigation systems, a typical valve is made of reinforced plastics or cast iron and has one-chamber over an EPDM membrane.

The valve is operated by controlling the volume of the water at its chamber. The headloss of the through flow is depending on the membrane geometry. When the chamber is empty of water, the membrane conform to the walls of the chamber, the water passage through the valve is fully open. In this case, pressure headloss across the valve is minimal. The specific headloss of fully opened valves are defined by the flow factor **Kv** as cited by most makers.

$$K_v = Q / (\sqrt{\Delta P}) \quad \text{Where,}$$

Q- Flow rate [m³/hr]

ΔP- Head loss [Kg/cm²]

When the chamber is partially full by water, the membrane swell and decrease the water passage inside the valve and increase the local headloss across the valve. When the chamber is full, the membrane closes the water passage and valve is closed.

The principle of operation is illustrated in fig 1 below. Another single chamber design is shown in fig 2 below.

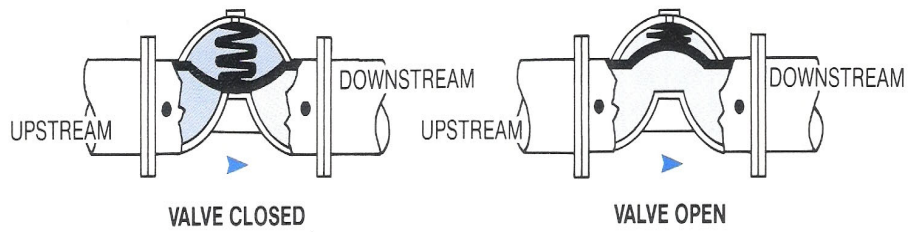

Fig 1: Hydraulic Valves: Principle of Operation

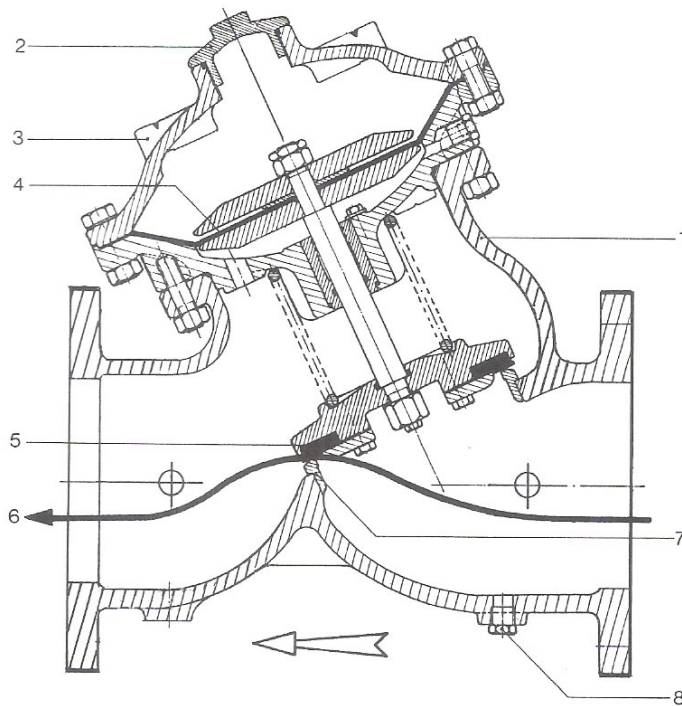

Fig 2: Globe Type Hydraulic Valve with one-chamber

Pilot Valves

Pilot valves are devices that control hydraulic valve according to external signal.

As explained above, the control of a hydraulic valve is done by changing the water volume inside its chamber. Possibly, the drained (to open the valve wider), filled (to close it) or maintained (to hold).

The signals are communicate through few media: electrical, hydraulic or pneumatic.

Practically, in low volume irrigation, only solenoids (electric) and hydraulic pressure sensors are used.

This paper deals with one pilot application namely, Pressure Reducing. PR pilots are divided to 2-way and 3-way as explained here below. Selection of either configuration depends on the application and field condition. The two configurations are shown schematically in fig.3.

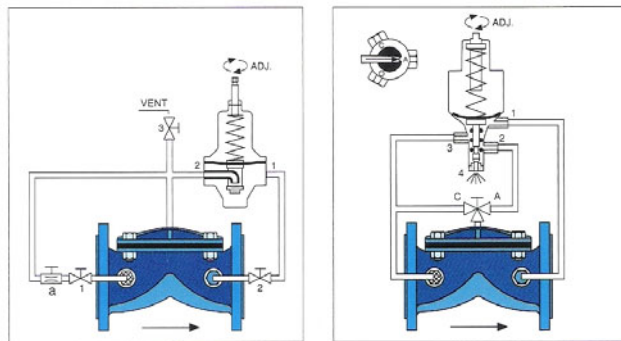

Fig 3: Schematic 2-way & 3-way configurations

Two-Way Pressure Reducing Pilot

2-way PR pilot is illustrated schematically in fig 4 below. The ports connections are as follow:

In- is connected to the chamber which has a continuous supply of upstream flow.

Out- drains the chamber to the downstream.

Thus, when downstream pressure is too high, the pilot is closed as shown below. The chamber is filled with upstream water and consequently the membrane suffocates the through flow of the valve.

When downstream pressure is lower the pilot opens as shown to allow draining of the chamber and consequently increasing the water passage through the valve.

Note that draining of the chamber is possible only if the inflow to the chamber (not shown) is much less than the outflow. This feature is represented by the needle valve (**a**) in the illustration above. In all new designs the needle valve is replaced by a small orifice and screen filter.

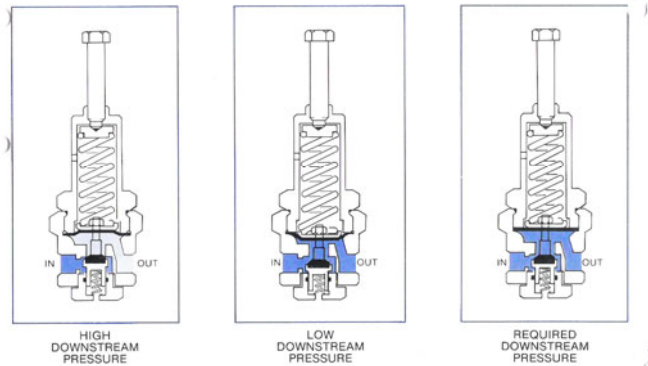

Fig 4: Schematic Operation of PR 2-way Pilot Valve

The pros of the 2-way pilot valve are:

- Fast response to pressure modulations
- Relatively high precision: ± 0.2 bar.
- Integral design (that combines valve body and PR pilot into one unit) is possible, i.e. Aquanet valve.
- No spill of water.
- Excellent for modulating upstream pressure and alternating flow conditions.

The cons are found as well:

- The operational head loss in 2-way pilots is 0.5-1.0 bar.
- The valve passage is never fully open, thus the head loss is always above the flow factor.
- Considerable amounts of water flow through the pilot body and the tiny orifice (or needle valve). Clogging of that orifice eliminate the pilot! Thus, continuous maintenance is crucial.

Three-Way Pilots

A schematic 3-way PR pilot is shown in fig 5 below. Port 1 is connected to the downstream pressure (sensing pressure). Port 2 is connected to the chamber, port 3 is a vent to the atmosphere and port 4 is connected to the upstream pressure (operational pressure).

When the downstream pressure is low, the spring overcome the membrane, pushes the plunger down and allow connection between ports 2&3. The chamber drains to the air (by spilling water), the membrane let the valve open. Possibly, valve may remain fully open.

In case of high downstream pressure the membrane is pushed back, and the plunger moves upwards, connecting the chamber to the upstream pressure. Thus the valve is closed.

If the downstream pressure is within the "neutral zone" (see fig. 6) the plungers stay still, without water flow.

Thus, 3-way pilot has three downstream pressure zones : low, high and neutral. In normal conditions, low volume systems work constantly without considerable pressure modulations. Most of the time, the pressure is within the neutral zone keeping the pilot unchanged. In this case, there is no water flow, no risk of clogging and no water spill. 3-way pilots are excellent for low volume applications.

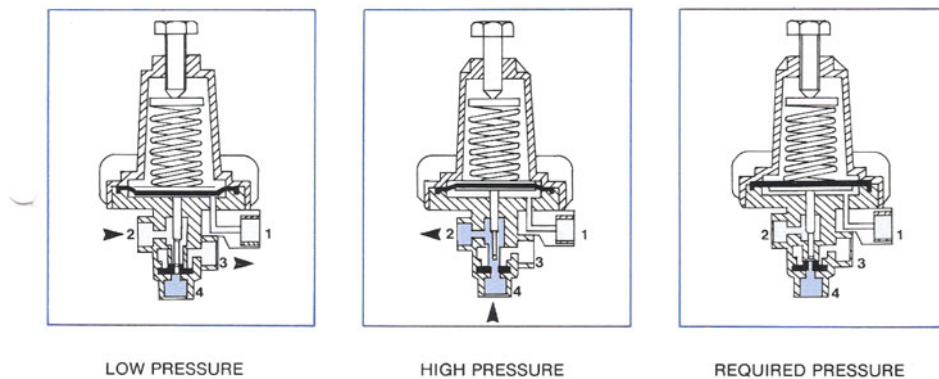

Fig 5: Schematic Operation of PR 3-way Pilot Valve

3-way pilot of any design has a built-in hysteresis. Hysteresis is a friction phenomenon that causes a different behavior of the system for increasing and decreasing branches. A typical hysteresis is shown in figure 6. **P1** and **P3** are the switching points. That means, that if the sensing pressure is less than **P1** the chamber drains to the atmosphere, and if it greater than **P3** the chamber is connected to the upstream pressure. If the downstream pressure is in the neutral zone between these values the chamber is disconnected from the other ports.

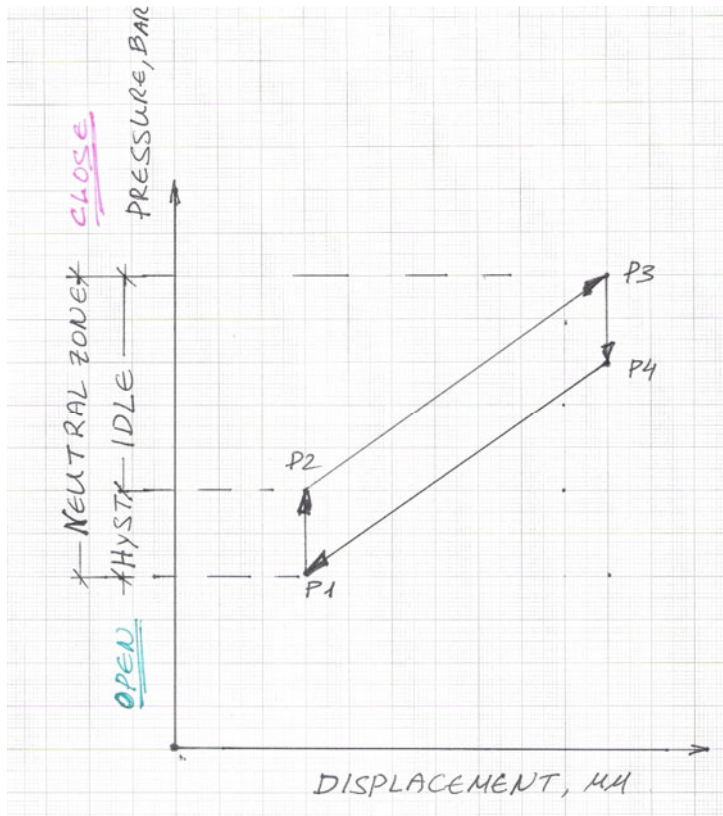

Fig 6: Characteristic diagram of a Pilot Valve

The data was collected using a 3-way pilot, as shown in fig 5. Port 1 (sensing port) was connected to a regulated pressure source. Port 2 was connected to an operation pressure source. When the sensing pressure was gradually increased the pilot valve switches from one port to the other- due to the movement of the plunger- at certain pressures. Same process was repeated while the sensing pressure was gradually decreased. The data is shown in table 1. This procedure was repeated for different set pressures.

Rep.1

Pressures:	[bars]		
Set Pressure	1.2 bar		
	<i>Switch</i>	<i>Switch</i>	Idle
Up ►	1	1.45	0.45
Up ►	1.1	1.5	0.4
Down ◀	0.85	1.25	0.4
Down ◀	0.9	1.3	0.4
Hysteresis	0.175	0.2	

Rep.2

Pressures:	[bars]		
Set Pressure	2.35 bar		
	<i>Switch</i>	<i>Switch</i>	Idle
Up ►	2.15	2.65	0.5
Up ►	2.2	2.65	0.45

Down ◀	2	2.45	0.45
Down ◀	2.1	2.6	0.5
Hysteresis	0.125	0.125	

Rep.3

Pressures:	[bars]		
Set Pressure	3.3 bar		
	<i>Switch</i>	<i>Switch</i>	Idle
Up ▶	3.1	3.6	0.5
Up ▶	3.15	3.65	0.5
Down ◀	2.95	3.4	0.45
Down ◀	2.95	3.45	0.5
Hysteresis	0.175	0.2	

Table 1: Measurements of idle and hysteresis Δp in different set points of the same pilot

A 3-way pilot closes and opens flow by means of rubber seal. Fig 7 shows a different design of 3-way pilot. The whole operation is done by small displacement of the plunger and its o-rings. Fig 8 shows a blow-up of the plunger in the neutral position. When it goes up or down it connects the passage to atmosphere/operating pressure.

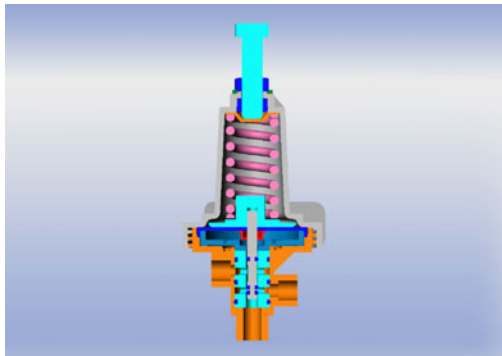

Fig 7: Crossection of a 3-way PR pilot valve

The idle pressure increment (fig 6) derived out of a predetermined displacement of the plunger against a loaded spring. The displacement is linear with the pressure increments in both directions.

The hysteresis resulted from the irreversible distortion energy that wasted as heat. The distortion of the rubber seal, o-ring in this case, is shown in fig 9. The "sluggish" distortion reversed when the plunger move to the opposite direction.

The hysteresis value can be controlled up to point. As many friction problems, it has few factors, part of them non-linear or chaotic. Thus, the "neutral zone" is not fixed, and may increase as things getting tough, materials age and surfaces deteriorate. Pilots with initial low hysteresis are superior, as they are more responsive and operate more smoothly.

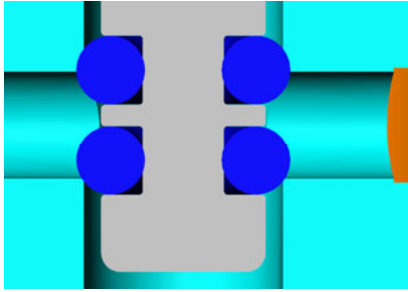

Fig 8: Blowup of the above crosssection shows: plunger, O-rings and water passages

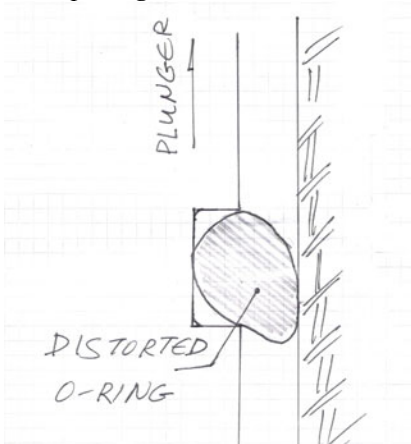

Fig 9: Explain of the Hysteresis Phenomenon in Pilot valves

The pros of the 3-way pilot valve are:

- The valve-chamber drains completely, enables minimum head loss in full flow.
- Operation use small water quantity.
- Relatively large water passages assure high clogging resistance.
- Good response to pressure modulations.
- In normal conditions acceptable precision: ± 0.3 bar.
- Excellent for steady flow and constant upstream pressure conditions.

The cons are:

- Spill of water.
- Minimum response range is ± 0.7 bar.
- Inherent hysteresis may increase response range up to ± 1.1 bar.

Comparison Table

	2-Way	3-Way
Use & Applications		

Upstream Pressure	Modulating	Constant
Applications	All	Especially PR,PS
Typical Market	Water supply, Industry, landscape	Ag, turf and crops Irrigation.
Precision & Repeatability		
Responding Speed	Fast	Medium
Friction	low	Medium
Hysteresis	Very low	medium
Overall	±0.2 atm	±0.3 atm
Head loss across Valve		
At low downstream pressure	Valve is <u>Never</u> Fully Open	Valve is Fully- Open
Operational headloss	0.5-1.0 atm	Null
Maintenance		
Passage	Ø1-2 mm	Equivalent Ø2.5mm
Filter	Necessary 120#-200#	Optional 40#-80#
Water throughflow	Constant	Small
Water Spill	None	Some

Practical Hints

- Use 3-way pilot if you doubt the water quality.
- Use 3-way for irrigation applications, especially low-volume systems.
- While using 2-way pilot- keep the inner filter clean at all time.
- Use 2-way pilot where the water quality is good (potable water, suburban supply systems).
- Use 2-way pilot where the pressure is modulating (urbane or suburban supply systems).
- When you consider using a 3-way pilot, check the range of sensitivity. Ask your dealer for data.
- Avoid using under size hydraulic valves. Consult your dealer.
- Always perform fine tuning of the pilot in extreme field conditions: maximum expected flow rate and lowest probable upstream pressure.