

# Lessons from Successful SCADA and Automation Projects

Charles M. Burt<sup>1</sup> and Xianshu Piao<sup>2</sup>

## ABSTRACT

ITRC has designed, specified and assisted with installation, several dozen successful irrigation district automation and SCADA (Supervisory Control and Data Acquisition) projects in California, Oregon, Washington, Nevada, Arizona, and Colorado within the past 10 years. This paper is intended to acquaint people who are interested in SCADA with key concepts, to reduce their learning curve. The term “SCADA” encompasses many combinations and variations of remote monitoring and control. An emphasis on good planning, with the use of high quality equipment and expertise, will help guarantee a successful project.

## INTRODUCTION

Irrigation Association members work predominately in the farm or landscape/turf aspects of irrigation. Another huge arena of irrigation involves irrigation districts, which obtain, convey, and distribute irrigation water to farmers. SCADA systems in irrigation projects have been in existence for several decades. However, the vast majority of functional SCADA systems in irrigation districts have been installed within the last 10 years. Many of the lessons learned are applicable to on-farm and municipal SCADA system applications.

### Why SCADA?

There are probably three major reasons why so many irrigation districts are investing in SCADA:

1. Irrigation must retire “art” and shift to an industrial control process, in which real-time information is constantly used to make appropriate decisions. Reducing “art” in the process fulfills the need and desire to:
  - a. Reduce diversions, to maintain in-stream flows in the rivers.
  - b. Provide more flexibility in water delivery to farmers.
  - c. Reduce pumping costs.
  - d. Conserve water and sell the conservable water.
  - e. Remove the mystery of operation details, so that new employees can be easily trained, and so that managers can establish clear and measurable performance guidelines for canal/pipeline operators.
2. There is often a need for automation that requires computers (Programmable Logic Computers, or PLCs) at remote locations. Because it is the nature of computers,

---

<sup>1</sup> Professor, BioResource and Agricultural Engr. Dept. and Chairman, Irrigation Training and Research Center (ITRC). California Polytechnic State Univ. (Cal Poly), San Luis Obispo, CA 93407; [cburt@calpoly.edu](mailto:cburt@calpoly.edu)

<sup>2</sup> Controls Engineer. Cal Poly ITRC. [xpiao@calpoly.edu](mailto:xpiao@calpoly.edu)

electronics, sensors, and software programs to have occasional problems, it is prudent to remotely monitor their performance at such sites.

3. Some districts have key trouble spots where water levels or flow rates historically get too low or high. SCADA provides a means to remotely monitor those sites in real-time – minimizing labor, vehicle mileage, dust, etc. while improving response time to problems.

### SCADA CHARACTERISTICS

Some SCADA systems will be quite elaborate and involve automation, and others will simply be able to transmit data from remote locations. However, all SCADA systems have the following components, at a minimum:

1. A sensor
2. Some type of on-site apparatus that creates an electrical signal that can be transmitted
3. A local power supply to power the sensor and transmission unit
4. Some type of communication system, such as hard wire, radio, satellite, phone, etc.
5. A receiving unit on the other end of the communications
6. Some mechanism to display the information – which may be a simple alarm bell, computer screen, message on a pager, etc.

The components listed above would provide “remote monitoring” – which is one-way communication only. However, many systems (e.g., Figure 1) also include some type of control capability – which requires two-way communication.

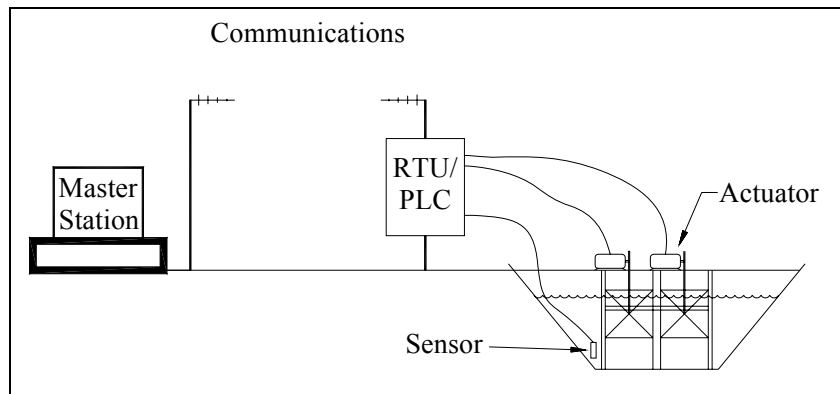

Figure 1. Conceptual elements of an irrigation district SCADA system that involves control.

Many people use the term “SCADA” to denote the collection and transmission of data, *plus* an automation process. An automation process may or may not require SCADA, so we prefer to separate the two (See Table 1). Not all of ITRC’s SCADA projects involve automation, and not all of our automation projects involve SCADA. That said, all of ITRC’s automation projects that use programmable logic controllers (PLCs) also incorporate SCADA for remote monitoring, alarms, and the ability to change target values.

Table 1. Variations between and within SCADA systems

Case	Basic Function	Frequency of Sensor Monitoring	Frequency of Data Transmission to Office
1 Monitor	Alarm for high/low values	Continuous	Only if alarm condition exists.
2 Monitor	Alarm for specific values such as height, position, temperature	As often as once/second, as seldom as once/15 min.	Only if alarm condition exists.
3 Monitor	Remote monitoring of specific values such as height, position, temperature. No alarming.	As often as once/second, and as seldom as once/day.	For river basins – often a few times/day. For irrigation districts – often once/minute.
4 Monitor	Cases (2) + (3)	1/sec – 1/day	Once/day remote monitoring can be over-ridden by an alarm exception at any time.
5 Monitor plus manual	Case (4) plus remote manual control of an actuator	1/sec – 1/15 min	1/30 sec – 1/30 minutes. Slower than 1/minute is outdated and cumbersome for operators.
6 Monitor plus Automation	Case (5) plus remote changing of target values for local, independent automation	1/sec – 1/15 min. With modern automation, 1/sec or more frequent is common.	1/30 sec – 1/30 minutes. Slower than 1/minute is outdated and cumbersome for operators.
7* Monitor plus Automation	Case (6) plus feed-forward between local controllers	1/sec – 1/15 min. With modern automation, 1/sec or more frequent is common.	1/30 sec – 1/30 minutes. Slower than 1/minute will often not work with feed-forward. <b><i>This is rarely found in an irrigation district.</i></b>
8* Monitor plus Automation	Case (4) plus centralized computation of gate/pump movements	1/sec – 1/15 min. With modern automation, 1/sec or more frequent is common.	1/sec – 1/15 min. <b><i>This is rarely found in an irrigation district.</i></b>

\* - Denotes forms of automation with few examples of sustained success in irrigation districts.

It is common for one SCADA system to incorporate several of the cases in Table 1.

### **Overview of Building a SCADA System with Local Automation (Case 6)**

An abbreviated flow chart for the process of building a SCADA system for Case 6 (of Table 1) can be seen in Figure 2. Within each of the action blocks are numerous steps. Within the box labeled “Perform Specific Field Tests”, for example, ITRC has several pages of procedures. Likewise, for checking the wiring and calibration of the field PLCs alone we have 12 pages of flow charts.

### **Components versus Systems**

Figure 2 illustrates that successful implementation of a SCADA system, especially one involving automation, is much more complicated than simply selecting a PLC and some sensors. SCADA

systems are composed of components that have hopefully been selected and connected to work as a seamless system to satisfy specific objectives.

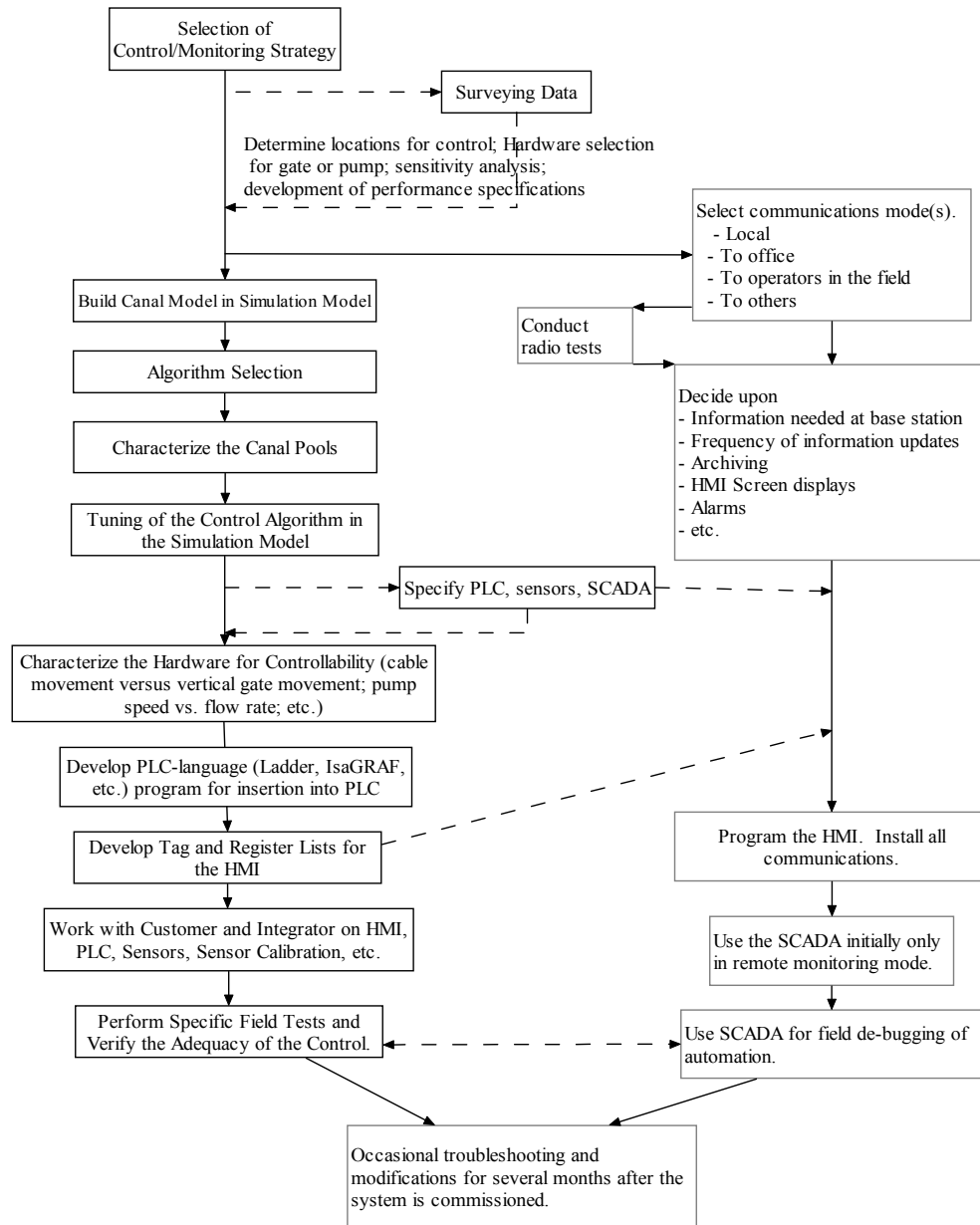

Figure 2. Outline for the Process of Design and Implementation of a Case 6 SCADA System.

The components must be carefully selected so that everything “matches”. For example,

1. A very good sensor might output a voltage signal, but that might be completely incompatible with a requirement that the signal must be transmitted over a 3000’ cable.
2. A specific brand of water level sensor may be excellent, but if a 10 psi sensor is selected when only a 1 psi sensor is needed, the resolution of the signal will only be 10% of what is possible.

3. 8-bit sensors connected to 16-bit computer input boards cannot give 16-bit resolution, or visa-versa.
4. If a control algorithm requires an average of 60 readings/minute, a PLC that is only capable of obtaining 60 readings in the last 10 seconds of the minute will provide different control capabilities than one that can obtain one reading each second during the 60-second period.
5. The power provided to a PLC must be capable of powering all the sensors, radio(s), PLC, heater, etc. in all weather conditions.
6. Sensors with proprietary software and communications won't easily fold into a complete system that can be updated and added to.

The examples show the following “matching” or “compatibility” requirements:

1. The hardware must be able to physically link together and communicate. This is the job of the “integrator”.
2. The hardware must be compatible with the control/monitoring objectives. This is the job of an *irrigation* automation control specialist, who must provide specifications to the “integrator”. Control specialists from the chemical, electrical, transportation, etc. industries have not been able to successfully apply their control logic to canal systems.

The emphasis with SCADA systems, in our opinion, is QUALITY, QUALITY, QUALITY – in specifiers, integrators, software, and hardware. Even in systems with the best-quality components, problems arise. The correct SCADA team can sort out those problems if there is a willingness to work together and an understanding of the system in its entirety.

Many of the components and “systems” sold for the farm irrigation SCADA market are one-of-a-kind, proprietary units of medium-low quality, that are not assembled or designed by a “team” that looks at the expanded needs for a farm. They are typically designed to measure/monitor/control one or two items that are sold by the same vendor that sells the communication system and office software. They are often not compatible with other brands; the result is that a farm may need many individual SCADA systems to accomplish what one good commercial, industrial SCADA system could provide.

### **Other Consideration**

Irrigation districts that have successfully implemented them typically quickly expand them and wonder how they survived without them. But there are also many problem cases. Classic problems are:

1. Cost overruns
2. Failure to achieve performance expectations
3. Failure to reduce operating costs in order to meet payback expectations
4. The thing just doesn't work right

Secondary problems include:

1. Scheduling errors
2. Interfacing problems
3. Incompatible equipment
4. Lack of acceptance
5. Adverse publicity

In our experience, the problems in irrigation districts have arisen because of one or all of the following:

1. Entities are looking for a “silver bullet” that will cure problems quickly and with little effort.
2. People focus on a few components rather than understanding that they need to consider a system.
3. There is no clear plan for the present and future.
4. Irrigation districts decide to use the “local electrician” because he/she is a nice person and dependable, instead of hiring an experienced integrator with ample successful experience in irrigation district application.
5. Districts (or local government agencies) invent their own sensors, hardware, and software.
6. Districts start too big, too fast.
7. Not everyone accepts the fact that problems will occur, and that there must be qualified people to diagnose problems, service equipment and software, and stick with the problems until they are solved. This takes an on-going budget.

As with any process, there are logical steps to follow in designing and implementing a SCADA system. These include:

1. Master planning
2. Precise specifications
3. Vendor qualification
4. Vendor selection
5. Adequate training and documentation
6. User tools for future changes
7. Spares and warranties
8. Continuous and near-exhaustive testing
9. Realistic schedules

The process can take a long time before any actual installation begins. If the planning is done properly, the installation can be accomplished in a few months. If the wrong people and planning are involved, the installation may never be completed satisfactorily. A few of the points above are explained in more detail, below.

Master Plan: A master plan identifies the need for automation, the degree of automation required, what other features are desired, and the budget and cost justification. This represents the guideline for all the work, so it is necessary to carefully understand which options are desired and why. The plan must also consider the impact on operation, instrumentation, training,

installation, interfaces to other utilities (such as electric utilities), public relations, manpower requirements, future expansion, and expected life of the new system.

Integrator: The component selection, matching, installation, and troubleshooting are so complicated that most successful SCADA projects have utilized an “integrator” that assumes responsibility for the complete package. The integrator generally understands communications, sensors, human-machine interfaces (HMI), actuators, etc. and can make certain that everything physically moves, measures properly, and communicates. It is extremely important to understand that when SCADA is used in a canal automation scheme, the SCADA integrator will rarely, if ever, understand canal hydraulics, simulation techniques, and control algorithms and algorithm tuning. These are separate functions that require an additional expert.

HMI: The Human-Machine Interface (HMI) – the software and screens in the office - is important. How easy is the system to operate? Are control and monitoring screens straightforward and is information easily accessible? For example, an alarm condition that is missed because it is mixed in with many nuisance alarms is as bad as one that is missed by the instrumentation. Can in-house people make simple changes to the screen displays?

Reliability: Reliability is a measure of the system’s ability to minimize downtime by avoiding failure, or at least to keep operating in a degraded mode by using special software and hardware such as an uninterruptible power supply (UPS) and a redundant master computer. The tradeoff includes weighing the extra cost of the additional equipment against the value of this function and the likelihood of an outright failure. No machine will run forever and eventually you will have to shut down your master at least for occasional checkups and preventive maintenance – managers should be prepared to live with these tradeoffs or buy reliability up front. ITRC has decided that for control variables in automated systems, it is essential to have a high level of redundancy in sensors, power supplies, and A/D converters. Yes, this costs extra and may reduce the number of sites that can be automated, but it ensures a better chance of success.

Maintenance: Maintainability is the ease with which fixes or changes can be made to your system. In the case of hardware, consider what you can fix yourself, what spares you may need, and how accessible the vendor is for factory returns and for minor upgrade contracts. Modularity helps maintenance. Placing sensors so that they can be removed for cleaning/inspections, and be replaced in exactly the same location without new calibration, is important.

## SUMMARY

The potential exists for new and expanded SCADA systems in their many combinations and variations of remote monitoring and control for irrigation districts and farms and large commercial/industrial/golf irrigation systems. However, in order for customers to fully utilize that potential, attention must be paid to all of the details – which, in many cases, can “make or break” a system. An emphasis on good planning, with the use of high quality equipment and expertise, will help guarantee a successful project.