



IRRIGATION SCHEDULING TECHNIQUES

Irrigation scheduling is a systematic method by which a producer can decide on when to irrigate and how much water to apply. The goal of an effective scheduling program is to supply the plants with sufficient water while minimizing loss to deep percolation or runoff. Irrigation scheduling depends on soil, crop, atmospheric, irrigation system and operational factors.

Proper irrigation scheduling requires a sound basis for making irrigation decisions. The level of sophistication for decision making ranges from personal experience to following neighbours' practices and techniques based on expensive computer-aided instruments that can assess soil, water and atmospheric parameters.

Irrigation scheduling techniques can be based on soil water measurement, meteorological data or monitoring plant stress. Conventional scheduling methods are to measure soil water content or to calculate or measure evapotranspiration rates. However, research in plant physiology has led to scheduling methods by monitoring leaf turgor pressure, trunk diameter and sap flow.

Soil Moisture Measurement

The many different methods of collecting soil moisture include neutron probe, time domain reflectometry (TDR), gravimetric, aquaterr probe, tensiometers, electrical resistance blocks and the hand feel method. The discussion in this factsheet will be limited to the methods that are practical for agricultural producers.

TDR, neutron and aquaterr probes are all expensive units (\$4,000 to \$7,000) that are often used by researchers but are not commonly used by producers.

Hand Feel Method

To measure soil moisture using the hand feel method, obtain a handful of soil and squeeze tightly. If it forms a ball, bounce it three times lightly in your palm. The relative soil moisture can be determined for the different soils by using Table 1.

The soil auger shown in Figure 1 can be used to obtain the soil samples at different depths.

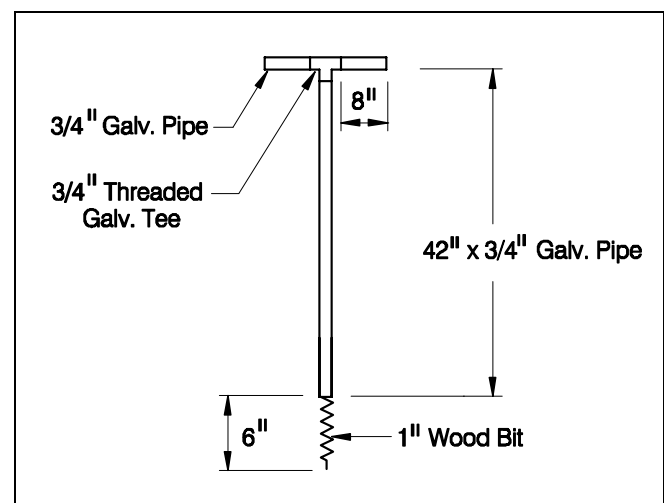

Figure 1 Small Soil Auger

| Table 1 Soil Moisture, Appearance and Description Chart | | | | |
|---|--|---|--|---|
| Available water ¹ | Feel or Appearance of Soil | | | |
| | Sand | Sandy loam | Loam/Silt loam | Clay loam/Clay |
| > 100% | Free water appears when soil is bounced in hand. | Free water is released with kneading. | Free water can be squeezed out. | Puddles; free water forms on surface. |
| 100% | Upon squeezing, no free water appears on soil, but wet outline of ball is left on hand. (1.0) ² | Appears very dark. Upon squeezing, no free water appears on soil, but wet outline of ball is left on hand. Makes short ribbon. (1.5) ² | Appears very dark. Upon squeezing, free water appears on soil, but wet outline of ball is left on hand. Will ribbon about 1 inch. (2.0) ² | Appears very dark. Upon squeezing, no free water appears on soil, but wet outline of ball is left on hand. Will ribbon about 2 inches. (2.5) ² |
| 75-100% | Tends to stick together slightly, sometimes forms a weak ball with pressure. (0.8 to 1.0) ² | Quite dark. Forms weak ball, breaks easily. Will not slick. (1.2 to 1.5) ² | Dark coloured. Forms a ball, is very pliable, slicks readily if high in clay. (1.5 to 2.0) ² | Dark coloured. Easily ribbons out between fingers, has slick feeling. (1.9 to 2.5) ² |
| 50-75% | Appears to be dry, will not form a ball with pressure. (0.5 to 0.8) ² | Fairly dark. Tends to form a ball with pressure but seldom holds together. (0.8 to 1.2) ² | Fairly dark. Forms a ball, somewhat plastic, will sometimes slick slightly with pressure. (1.0 to 1.5) ² | Fairly dark. Forms a ball, ribbons out between thumb and forefinger. (1.2 to 1.9) ² |
| 25-50% | Appears to be dry, will not form a ball with pressure. (0.2 to 0.5) ² | Light coloured. Appears to be dry, will not form a ball. (0.4 to 0.8) ² | Lightly coloured. Somewhat crumbly, but holds together with pressure. (0.5 to 1.0) ² | Slightly dark. Somewhat pliable, will ball under pressure. (0.6 to 1.2) ² |
| 0-25% | Dry, loose, single-grained, flows through fingers. (0 to 0.2) ² | Very slightly coloured. Dry loose, flows through fingers. (0 to 0.4) ² | Slightly coloured. Powdery, dry sometimes slightly crusted, but easily broken down into powdery condition. (0 to 0.5) ² | Slightly coloured. Hard, baked, cracked, sometimes has loose crumbs on surface. (0 to 0.6) ² |

¹ Available water is the difference between field capacity and permanent wilting point.

² Numbers in parentheses are available water contents expressed as inches of water per foot of soil depth.

Tensiometers

A tensiometer measures the soil water tension that can be related to the soil water content for specific soils. Figure 2 shows the relationship between the available water depletion and the soil matric potential (soil moisture tension).

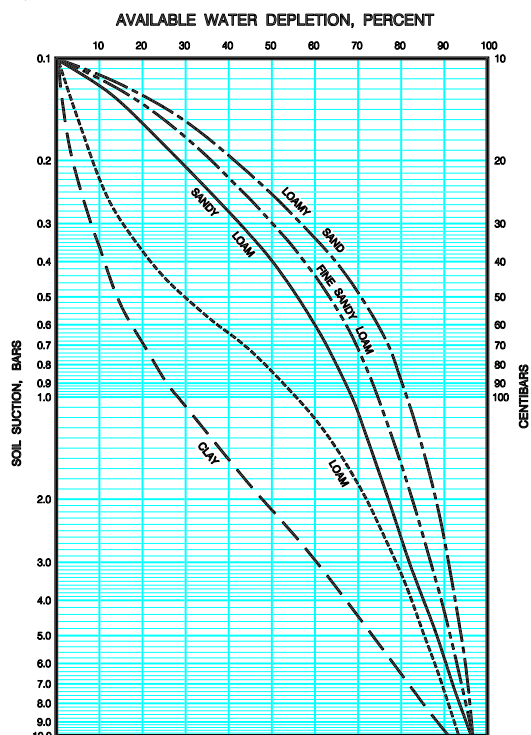

Figure 2. Influence of Available Soil Water on Soil Moisture Tension

The tensiometer is made of a closed tube with a special ceramic tip attached to one end. The tube can be sealed off at the top to create an airtight seal within the tube (Figure 3). As the soil dries and draws water from the tube, a vacuum gage registers the amount of suction indicating the level of soil moisture left in the soil.

The tube is filled with water and sealed. Installation must be done carefully to ensure that the ceramic tip is in complete contact with the soil. A pilot hole is augered or bored to the proper depth, a soil-water slurry mixed and put into the hole and the tensiometer tip pushed into this slurry.

When the ceramic tip comes to a moisture equilibrium with the surrounding soil, the gauge registers the soil tension. Soil wetting and drying results in movement of the vacuum gauge. Tensiometers are responsive to soil water tensions of 5 to 70 centibars (cbars). The practical operating range is from 0 to 75 cbars. Zero indicates that the soil is saturated. Readings of 10 correspond to field capacity for coarse textured soils while readings of 30 are at field capacity for fine textured soils. The upper limit of 75 cbars indicates that as much as 90% of the available water has been used for coarse soils but only 30% depleted for the fine textured soils. Refer to [Factsheet 577.100-2 Irrigation Scheduling with Tensiometers](#) for detailed information on soil moisture tension.

Calibration of the specific soil type must be done to establish the relationship between soil water content and soil water tension.



Figure 3. Tensiometer

Tensiometers are therefore limited to use in coarse textured soils or in high frequency irrigation regimes where the soil moisture is kept at higher levels, such as, in drip or center pivot irrigation.

Routine maintenance is critical to ensure successful use. The liquid in the tube must be periodically refilled and the air bubbles removed with the aid of a hand pump.

Electrical Resistance Blocks

The new generation of electrical resistance blocks have been developed and are under the trade name of Watermark (Figure 4). Watermarks measure the electrical resistance to current flow between electrodes embedded in a material resembling fine sand surrounded by a synthetic porous material.



Figure 4 Electrical Resistance Block

The blocks are installed in the soil in a similar procedure to installing a tensiometer. The blocks must make good contact with the soil, and the pilot hole with the wire leads should be refilled and tamped to prevent surface moisture from collecting around the blocks. Readings are taken by attaching a special resistance meter to the wire leads, setting the soil temperature and pushing a button to initiate current flow.

High resistance readings mean lower block water content; therefore, higher soil water tension. The Watermark will give higher values for dry soil conditions and low readings for wet conditions, similar to tensiometers. Calibration with the specific soil type must be done to establish the relationship between soil water content and tension.

Watermarks require little maintenance and can be left in the soil under freezing conditions. The Watermarks are responsive to soil water tensions of 40 to 125 cbars, and therefore well-suited for heavier soils.

Locations of Soil Moisture Monitoring Devices

A soil moisture monitoring site should be established in a part of the field that is indicative of the majority of the field conditions. Where two or more predominant soil types are present, more than one soil moisture site should be considered. Ideally, each distinct area will be managed separately.

Depending on the plant's maximum rooting depth and the soil type present, more than one sensor at a monitoring site may be required. All deep-rooted plants, such as fruit trees, should have two monitoring devices per site – one at 30 cm (12 in) and the other at 60 cm (24 in). Soil moisture should be measured at $\frac{2}{3}$ of the distance from the trunk to the canopy drip line.

Normally, tensiometers and Watermarks are installed at two different depths to develop a zone of moisture control. For most crops, the soil moisture should be measured at a depth of $\frac{1}{4}$ to $\frac{2}{3}$ of rooting depths greater than 2 feet; therefore, two soil measuring units should be installed: one at a depth of approximately 250 to 300 mm and the other at $\frac{2}{3}$ of the plant rooting depth.

The irrigation system should be scheduled using information from a representative area, not just the driest part of the field.

Collecting Meteorological Data

Water budgeting is a widely promoted method of irrigation scheduling. This method involves monitoring the additions and losses to the crop area and maintaining a favourable soil water level. The most important component of water budgeting is to accurately determine the crop water use or evapotranspiration (ET).

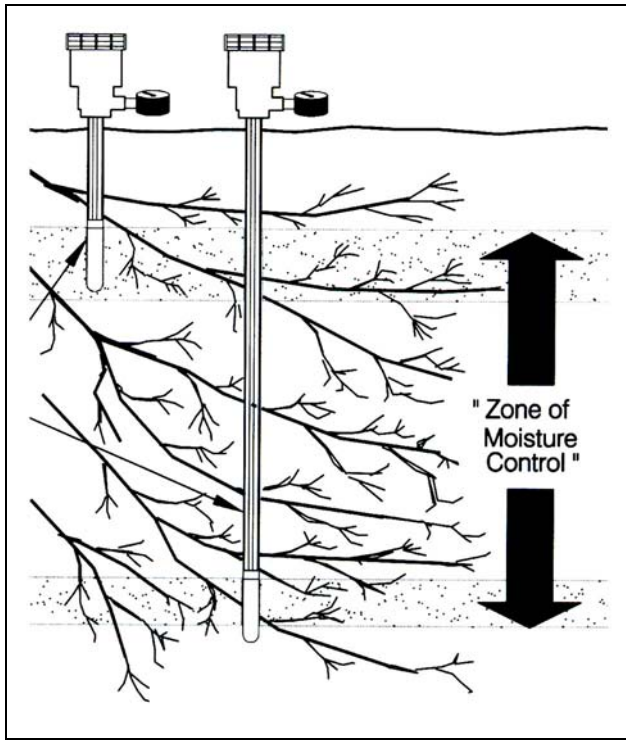

Figure 5. Soil Moisture Measuring

Plant Based Monitoring

There are a number of plant based indexes that can be used to determine whether irrigation is required. The most obvious is general plant appearance. Retardation in foliar growth or fruit development is an indicator that the plant could be experiencing water stress.

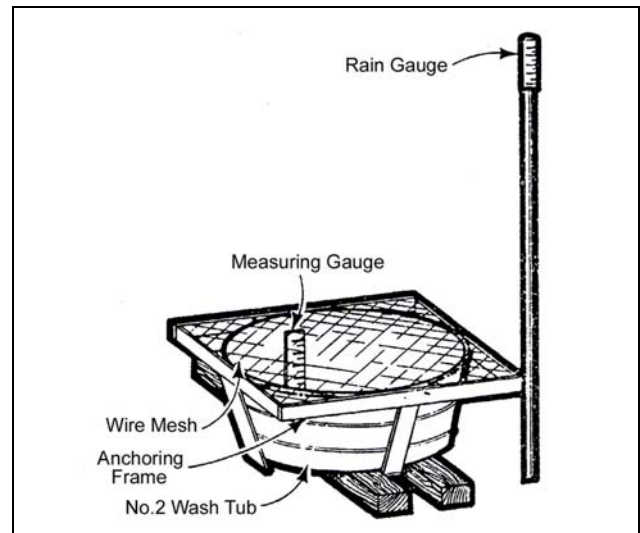

Figure 6. Evaporation Pan

ET can be calculated using sensors to collect radiation, wind, temperature and relative humidity data. This information can be imported into a computer to calculate daily ET. While the calculation method is often employed where weather stations have been established, (research stations) more often ET information is gathered by using evaporimeters.

Figures 6 and 7 indicate two types of evaporimeters. The evaporation pan should be monitored weekly and data is usually recorded manually. The atmometer can be read manually or be hooked to a computer or data logger to provide the information electronically. Evaporimeter data cannot be correlated to crop water use directly. Crop coefficients are used to adjust data for growth stage and seasonal changes. Table 2 provides crop coefficients for various crops at full cover conditions.



Figure 7. Atmometer

Real-time daily reference ET (ET_0) data is now available at www.farmwest.com from over 80 climate stations across British Columbia. The ET_0 is based on a grass crop, and therefore needs to be multiplied by an appropriate crop coefficient specific to the desired crop. Refer to Table 2 for crop coefficients. Refer to [Factsheet No. 577.100-5 Crop Coefficients for Use in Irrigation Scheduling](#) for more information on how to use ET to schedule irrigation.

Pressure Bomb

A pressure chamber or pressure bomb measures the water status in plant leaves. Several readings must be taken with this unit in order to characterize the status of a field. Readings will also change drastically during the day. Readings are lowest just before sunrise and increase rapidly until solar noon. Critical mid-day readings must be established for the crops for irrigation to be scheduled effective with this method.

Infrared Thermometers

This technique measures the surface temperature of a crop canopy with making direct physical contact. Measurements are based on the principle that objects

emit radiation in proportion to its surface temperature. The plant canopy temperature responds to air temperature and the form of this response can be used to assess plant water status.

| CROP | | FACTOR | CROP | | FACTOR |
|-----------------------|---------------------------|-------------|--------------|----------------------|-------------|
| Alfalfa and grass hay | | 0.95 | Onion | (dry) | 0.70 |
| Apple | (with cover crop) | 1.05 | | (green) | 0.80 |
| | (without cover crop) | 0.90 | Pasture | | 0.95 |
| Apricot | (with cover crop) | 1.00 | Peach | (with cover crop) | 1.00 |
| | (without cover crop) | 0.85 | | (without cover crop) | 0.85 |
| Asparagus | (after full fern) | 0.90 | Peas | | 1.00 - 1.05 |
| Cherry | (with cover crop) | 1.05 | Pear & Plum | (with cover crop) | 1.00 |
| | (without cover crop) | 0.90 | | (without cover crop) | 0.85 |
| Corn | (grain and sweet) | 0.95 | Potato | | 1.00 |
| Grape | (with cover crop) | 0.95 - 1.00 | Raspberry | | 1.00 |
| | (without cover crop) | 0.70 | Small grains | | 0.90 - 0.95 |
| Hops | (after reaching top wire) | 1.40 - 1.60 | Strawberry | | 0.40 - 0.45 |
| Mint | | 0.95 - 1.00 | Turfgrass | | 0.80 |

NOTE: Given crop factors are for full cover conditions. Over-irrigation will occur when used for early- and late-season conditions, but should be used as a rough guideline as to the *minimum* interval between irrigations early and later in the season.

Heat Pulse Sap Flow

The flow of water from the soil through trees is monitored by measuring how rapidly a pulse of heat is transported by the sap flow up the trunk. A ½ sec heat pulse is applied by a miniature heater imbedded radially into the trunk and the rate of sap flow is determined from the time it takes the pulse to reach a series of thermistors located a short distance above the heater. This procedure has provided an accurate measurement of daily water use by trees.

Turgor Pressure Sensor

A miniature displacement sensor attached to a leaf is used to measure reductions in leaf thickness, and thus turgor pressure, a water stress of the plant increases. An increase in the rate at which leaf thickness changes indicates the need to irrigate and is also used to determine irrigation duration.

To operate effectively, the method requires careful selection of a fully exposed leaf which accurately represents the average response for the entire tree throughout the day. It is claimed that such a system is

capable of reacting almost immediately to the onset of plant water stress, thereby preventing stomatal closure. However, under conditions of high evaporative demand, leaf turgor pressure may decrease despite a well watered soil and may trigger irrigation unnecessarily.

Dendrometer

A dendrometer is a sensitive dial gauge attached to the trunk or branch of a tree for measuring small changes in diameter as water status of the plant changes during the day. In a manner similar to the leaf thickness sensor discussed previously, the need for and the amount of irrigation can be determined from the change in diameter which occurs over a certain time period (usually from morning to noon). This procedure does not detect water stress as rapidly as the leaf thickness method but provides a more integrated measurement of conditions being experienced by the entire tree. Research efforts are aimed at relating diameter changes to irrigation requirements.

FOR FURTHER INFORMATION CONTACT

Ted van der Gulik, Senior Engineer
 Phone: (604) 556-3112
 Email: Ted.vanderGulik@gov.bc.ca

RESOURCE MANAGEMENT BRANCH

Ministry of Agriculture and Lands
 1767 Angus Campbell Road
 Abbotsford, B.C. V3G 2M3