



Issued August 2007

Cover photo: LUNKERS provide streambank stability and edge-cover aquatic habitat.

Advisory Note

Techniques and approaches contained in this handbook are not all-inclusive, nor universally applicable. Designing stream restorations requires appropriate training and experience, especially to identify conditions where various approaches, tools, and techniques are most applicable, as well as their limitations for design. Note also that product names are included only to show type and availability and do not constitute endorsement for their specific use.

Contents

Purpose	TS140-1
Introduction	TS140-1
Geomorphic design considerations	TS140-1
Design and construction	TS140-2
Materials and equipment	TS140-2
Construction of LUNKERS units.....	TS140-3
Placement of LUNKERS units	TS140-9
Conclusion	TS140-9

Figures

Figure TS140-1	LUNKERS being installed as part of a bank stabilization project	TS140-1
Figure TS140-2	LUNKERS installed over a stone base	TS140-2
Figure TS140-3	LUNKERS being installed “in the wet”	TS140-3
Figure TS140-4	Completed LUNKERS structure views	TS140-4
Figure TS140-5	Step 1: LUNKERS construction concept plan	TS140-5
Figure TS140-6	Step 2: LUNKERS construction concept plan	TS140-6
Figure TS140-7	Step 3: LUNKERS construction concept plan	TS140-7
Figure TS140-8	Step 4: LUNKERS construction concept plan	TS140-8

Purpose

Little Underwater Neighborhood Keepers Encompassing Rheotactic Salmonids (LUNKERS) are a technique to provide both streambank stability and edge cover aquatic habitat. While their use has primarily focused on providing trout habitat, they are applicable to other species, as well. This technical supplement provides guidance for the analysis, design, and installation of these structures. Particular focus is on the placement, anchoring, and finish-grading of LUNKERS structures. A step-by-step design procedure is provided.

Introduction

LUNKERS were introduced in 1982 by the Wisconsin Department of Natural Resources fisheries personnel as an alternative methodology to habitat improvement techniques then in use in trout streams. They are constructed structures that provide fish habitat in the form of edge cover. These structures resemble stout construction pallets (fig. TS140-1). While they are often made out of wood, stone has also been used successfully. They are used in sets and are often incorporated into other bank stabilization measures. In figure

TS140-1(b), the LUNKERS are under the stone. The arrow points to one that can be seen in the picture. While their actual name is LUNKERS, the individual units are often referred to simply as a LUNKER. While their use is often associated with cold-water fisheries, they have been applied to many sites throughout the United States.

Geomorphic design considerations

For LUNKERS to function properly and provide the intended benefits, consideration must be given to their location and placement. With some exceptions, most of the criteria in use have been developed as rules of thumb by experience. The criteria that determine whether LUNKERS are an appropriate project element include:

Stream gradient and flow—LUNKERS depend on flow entering the upstream end of the structure, then sweeping beneath and through them to maintain the underbank void created by the spacer blocks. LUNKERS should not be used if the current is not fast enough or the LUNKERS cannot be constructed to produce adequate current velocities that both

Figure TS140-1 (a) LUNKERS being installed as part of a bank stabilization project; (b) Completed LUNKERS project; LUNKERS are under the stone (Photo courtesy of Mike Martyn, USACE)

(a)



(b)



discourage new sediment deposition and also mobilize previously accumulated sediments. It may be necessary to place in channel boulders or use flow deflectors to force flows through the structure. These should be positioned during construction.

Channel substrate and surrounding land elevation—Traditional LUNKERS placement involves setting of the structure on a firm base to ensure stability. In low-gradient streams where post settlement alluvium is often several feet deep, LUNKERS may be installed into an excavated portion of the streambed and into the bank. However, in many stream systems, it will be necessary to install a stone base that is keyed into the bed at a depth that takes into consideration any anticipated scour. More information on stone sizing and scour calculations is provided in [NEH654 TS14C](#) and [14B](#), respectively. Figure TS14O-2 shows LUNKERS being installed over a rock base. The construction area had been dewatered when this photograph was taken.

Sinuosity—LUNKERS function optimally when placed on the actively eroding bank or outside bend. The lower two-thirds of a bend are preferable. This ensures

that the water flow and force will always be directed into and through the structure. They generally should not be placed in straight reaches to provide overhead cover unless measures, such as low deflectors, can be used to direct water flow into the structure.

Depth—The primary building component of LUNKERS is rough lumber. The permanence of the structure is maintained by complete immersion beneath the water surface. Periodic wetting and drying will encourage premature decay and eventual failure. Installation must result in the top planks being completely submerged below the known low water stage. The minimum depth necessary is generally 1.5 feet. Grade control structures have been successfully used to maintain the necessary depth. Additional guidance for the design of grade control structures is provided in [NEH654 TS14G](#).

Design and construction

Materials and equipment

Materials and equipment used to successfully construct and install LUNKERS vary, but some general guidelines are as follows:

LUNKERS material—The usual building component is rough-sawn and untreated wood. Oak is preferable due to its density, which contributes to the structure's ability to be handled by heavy equipment, withstand considerable weight placed on it, and resistance to rot. Newly cut (green) oak is often specified for ease of construction, since dried wood is difficult to drive nails into and may require screws.

Stone—Typically, stone is used to provide a firm base for the LUNKERS. The design and placement of stone is described in [NEH654 TS14K](#). Since the LUNKERS typically are constructed out of wood and will float if not secured, large anchor stone is also used to hold them in place. This is typically cut stone to achieve a firm contact. This is especially important if the LUNKERS units are to be placed without dewatering the site. In addition, soil anchors can be used to provide further anchoring.

Figure TS14O-2 LUNKERS installed over a stone base



Additional bank protection—LUNKERS are rarely used by themselves. They are often part of larger bank stabilization or riparian restoration projects. These wider projects may range from grass seed and erosion fabric to more complex plantings and soil bioengineering practices. Therefore, it may be important to include these practices to achieve the ecological restoration goals for the project.

Equipment—Typical hand tools used in most LUNKERS installations include shovels, pry bars, picks, and chain saws. However, the size of the materials, as well as the grading and excavation that are typically required, necessitates the use of heavy construction equipment, as well. Typically, an excavator or a backhoe is used. Buckets are commonly modified to facilitate the placement of the LUNKERS (fig. TS140–3). Note the forks incorporated into the bucket that keeps the LUNKERS level and the anchor stones in place.

Figure TS140–3 LUNKERS being installed “in the wet”



Construction of LUNKERS units

The following is a step-by-step procedure for constructing a LUNKERS unit. The procedures used to construct these structures are often modified based on the available material. Figure TS140–4 shows views of a typical completed LUNKERS structure.

Figure TS140–5 provides conceptual plans for the construction of LUNKERS.

Step 1 Build a spacer (Note: three equal-sized spacers are needed for each LUNKERS) (fig. TS140–5a).

Measure and cut two 6-inch lengths from the 6- by 8-inch beam to form two rectangular blocks.

Measure and cut the *bottom piece* from one of the 2- by 8-inch planks. This piece will be approximately 24 to 30 inches in length; however, the exact length of each piece depends on the recommended size of the LUNKERS.

Measure and cut the *top piece* from one of the 2- by 8-inch planks. This piece must be 50 percent longer than the bottom piece. (Example: if a 24-inch bottom piece is cut, then this piece must be 36 inches.)

Place the *bottom piece* so that one end fits flush with each of the 8-inch side of each of the rectangular blocks. Secure with two or three nails on each end. The spacer will now look like a low bench or table.

Flip the table over, and place the top piece cut above, flush to what will be the *streamside* of the LUNKERS. There will be an overhang, past the second block. (This will be the *bankside* of the LUNKERS) Secure to each block with two or three nails.

Repeat the above steps to result in three equal-sized spacers.

Step 2 Form the bottom of the LUNKERS (fig. TS140-5b).

Bridge the three spacers across the *bottom pieces*, using a 2- by 8-inch plank. Be certain the length of the plank is flush with the *streamside* of the spacer and that the spacers are evenly placed. Secure the plank with nails above the rectangular blocks, taking care not to hit previously driven nails.

Bridge the three spacers across the bottom at the second set of blocks, using another 2- by 8-inch plank. Be certain the plank is flush with the *bankside* of the spacer. Secure each plank with nails above the rectangular blocks. The bottom of the LUNKERS is now complete.

Step 3 Assemble the LUNKERS (fig. TS140-5c).

Form the top of the LUNKERS, flip the LUNKERS bottom over. Bridge the three spacers above the blocks with two 2- by 8-inch planks as done in step one, ignoring the overhang. Secure with nails.

Use a third 2- by 8-inch plank, placed evenly between the two top planks, and secure with two or three nails to each spacer. Depending on

the size of the LUNKERS, there may or may not be spaces between the three top planks. The top of the LUNKERS is now complete.

Step 4 Prepare the LUNKERS for placement (fig. TS140-5d).

Finish the LUNKERS according to the project's needs. In some cases, it is necessary to install two to four standard length rods to help anchor the LUNKERS into the streambed. Start by drilling two 9/16-inch holes in the top plank of the outer two spacers on the *streamside*. These holes should be placed on the inside of the streamside plank, as close to the *streamside* rectangular blocks as possible, without drilling into the blocks themselves.

If needed, drill two 9/16-inch holes in the top plank of the outer two spacers on the *bankside*. These holes should be placed on the inside of the *bankside* plank, as close to the *bankside* rectangular blocks as possible.

If needed, drill holes to attach soil anchors.

Install the cover board on the bankside of the LUNKERS, covering the openings under the overhang. Nail in place.

Figure TS140-4 Completed LUNKERS structure

(a) Front view

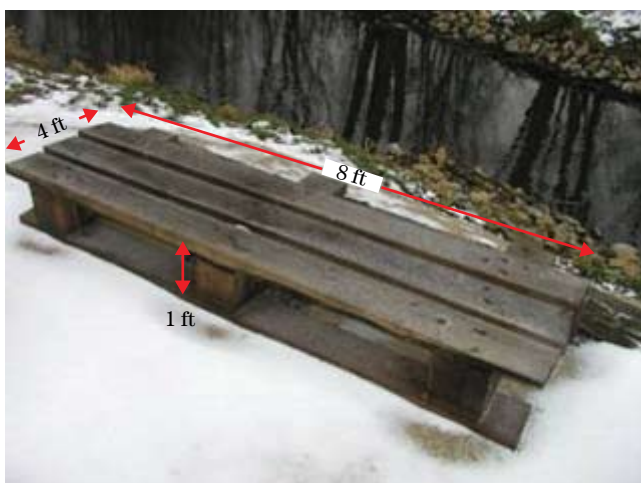

(b) Side view

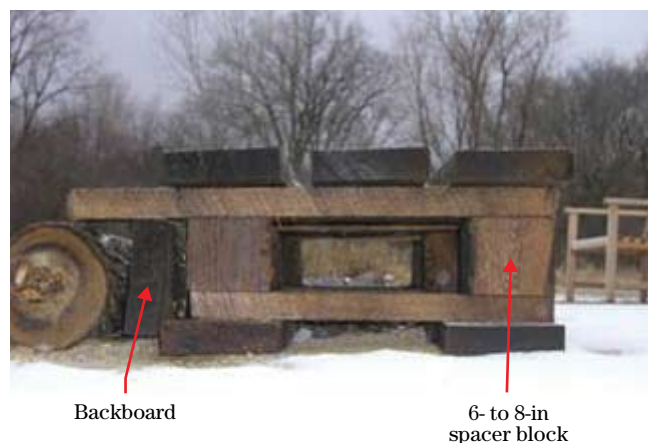

Figure TS140-5 LUNKERS construction concept plan

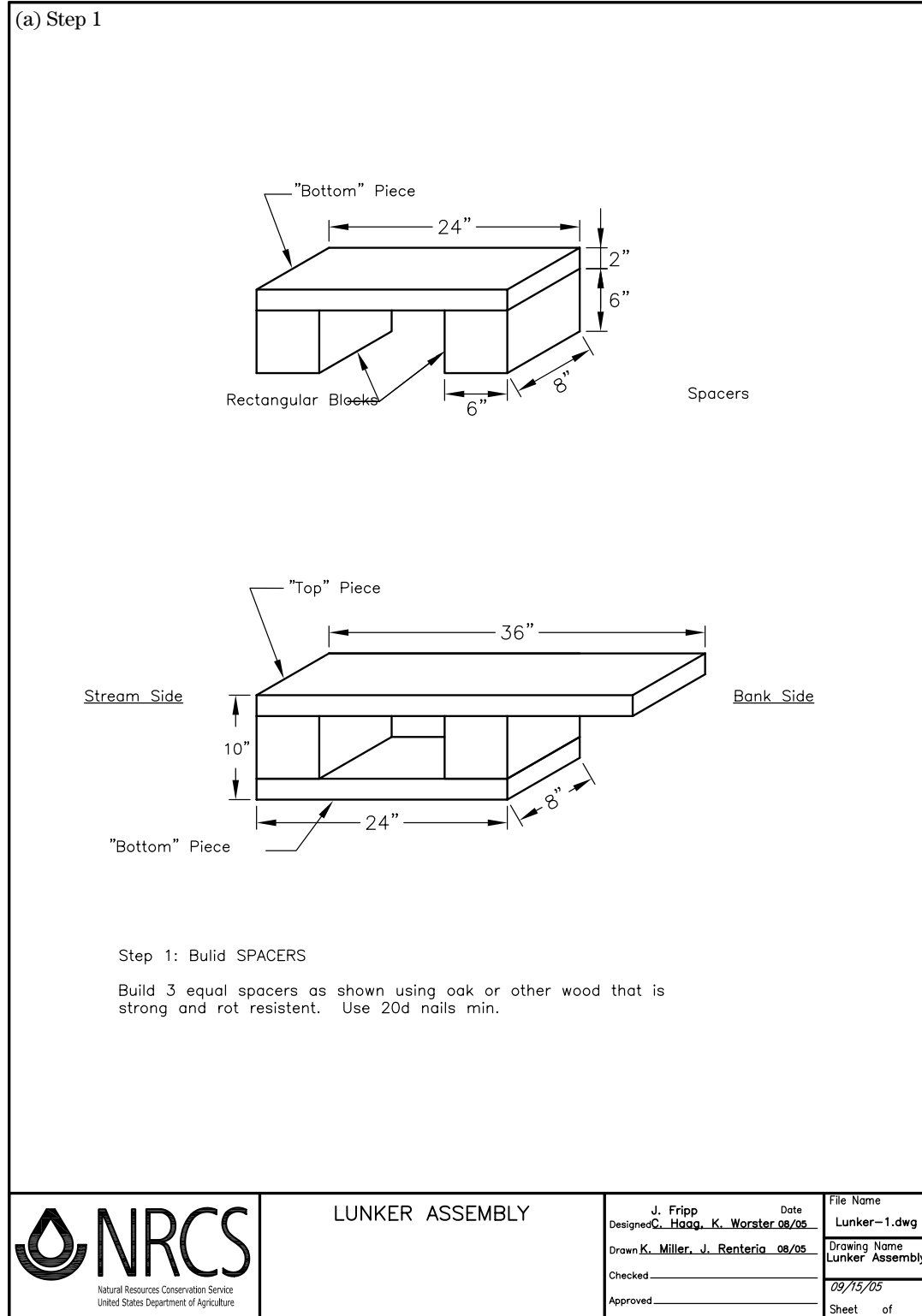

Figure TS140-5 LUNKERS construction concept plan—Continued

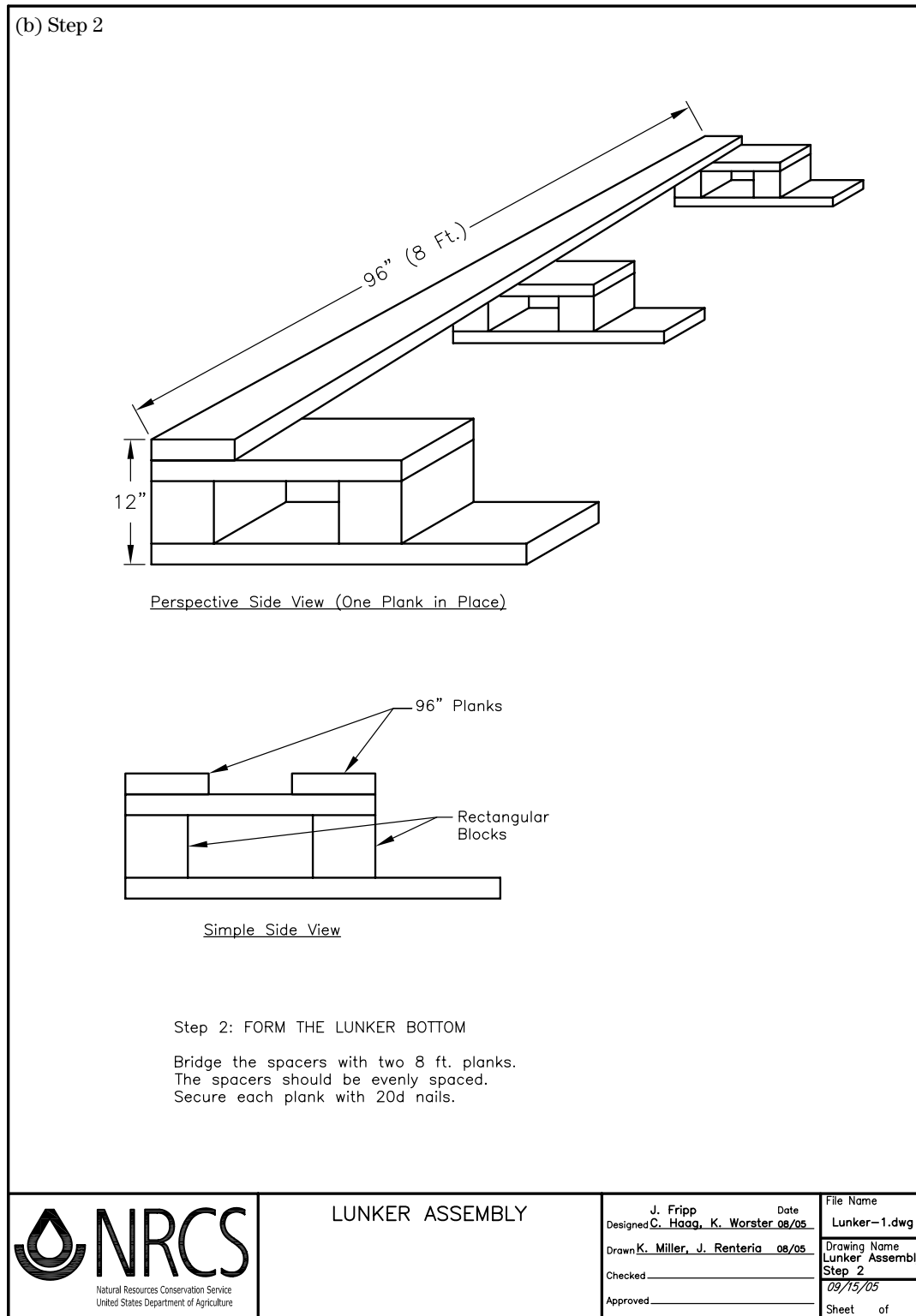

Figure TS140-5 Step 3: LUNKERS construction concept plan—Continued

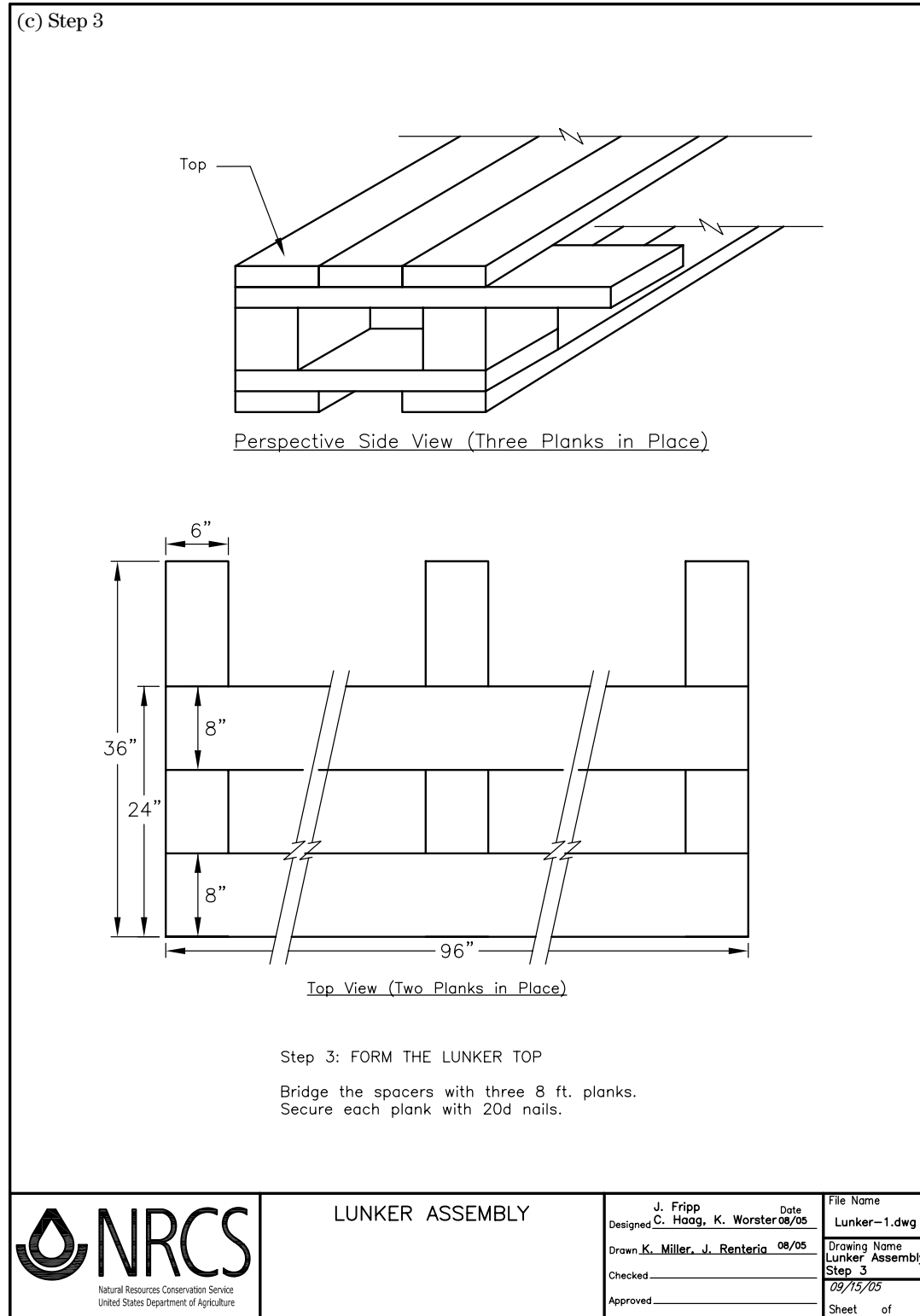
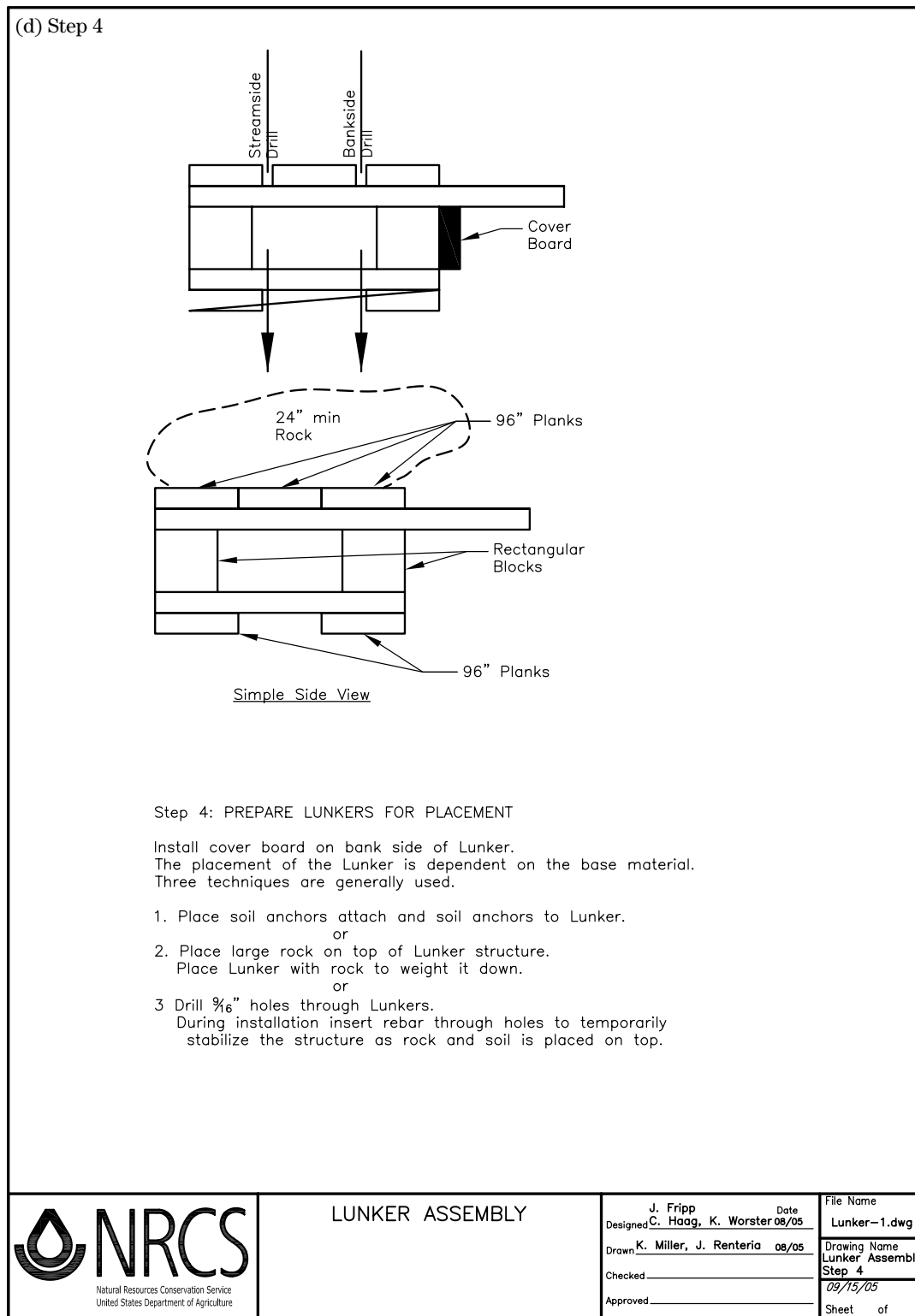

Figure TS140-5 Step 4: LUNKERS construction concept plan—Continued



Placement of LUNKERS units

The placement of LUNKERS structures follows the preparation of the bank by removal of all undesirable trees and debris. A trench that will receive the structures must be excavated into the bed and bank. It may be necessary to place a graded stone riprap base for the LUNKERS. The design of this stone should consider anticipated scour in the bend. Additional information on the use of stone is provided in [NEH654 TS14K](#). The resulting excavated area and base should be below the low-water level so that the structure is covered under normal low flows.

It is best for the structures to be placed so that the current will flow through them. Before excavation, designers may track the current by using a floating twig or wooden block, as it follows the targeted bank; then flag the upstream end as a guide for excavation. Boulders may be used to force flows through the LUNKERS. During construction, flexibility in placement of these boulders is essential. LUNKERS are typically used in a sequence. Three to four units is a common set. If too few are used, there may not be sufficient flows to flush sediment through the structure. If too many are linked together, the current that runs through the last (downstream) structure may lack sufficient energy to scour, so that the last structure in effect becomes a sediment trap.

Once the receiving area is prepared, the excavator lifts and delivers the LUNKERS to the trench, where it is hand placed to rest in its final orientation. The 4-foot perpendicular stringers will abut the old bank and serve as anchor points. Metal rods can be driven into the stream bottom to pin the LUNKERS to the streambed. Large stone is placed to anchor the structure. Depending on the forces expected from the stream, it may be necessary to include soil anchors to provide additional stability. More information on the design and application of soil anchors is provided in [NEH654 TS14E](#).

A well-distributed gradation of rock riprap is then placed in the existing space from the back edge of the face rock to the preexisting old bank edge. Minimum rock fill thickness is 18 inches. This ensures that the structure will not be isolated by water backcutting during flood events. The backboard of the LUNKERS prohibits the unintentional filling of the open space by

rock or sediment. Soil bioengineering practices may be installed above the structures. More information on soil bioengineering practices is provided in [NEH654 TS14I](#).

It is optimal to place the LUNKERS without dewatering the site, or in the wet, as this allows the designer to perform small adjustments on the flow deflectors. Placement during baseflows also assures that the structure will remain underwater and not be subject to damaging wetting and drying cycles.

Conclusion

Overall, LUNKERS have been a reliable feature of many stream habitat restoration and enhancement projects for more than 20 years. Since 2000, Targeted Management Runoff (TRM) projects on the West Branch of the Sugar River in southwestern Wisconsin have resulted in the placement of 1,020 LUNKERS. No specific, comprehensive evaluation of the permanence and functional success of the LUNKERS have been conducted, but anecdotal observations taken during fisheries surveys have noted that the structures are stable and show no significant backcutting, lateral erosion, or loss of backfill in the bank.

