

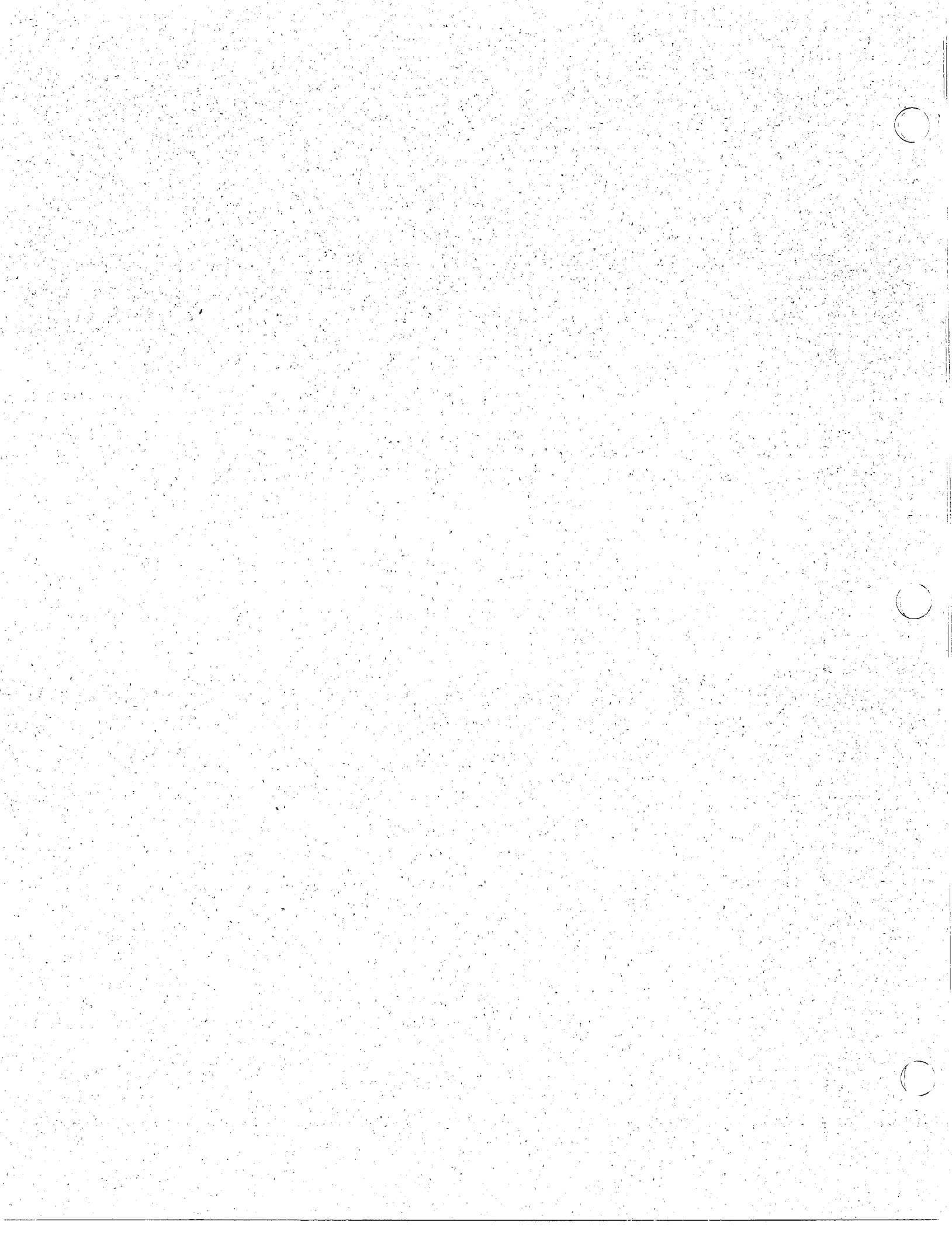

IRRIGATION HYDRAULICS

Instructor's Manual

Hunter® Irrigation Design Education Module



Irrigation Hydraulics



Instructor's Manual

Notes to the Instructor

The purpose of this manual is to give the instructor a guide to the material as well as a guide to the presentation of the lessons.

Presentation Time

It is recommended that this module be presented in one of two formats:

- 1) The short presentation is without sample problems attempted or discussed during the presentation. The estimated presentation time is one hour +/- ten minutes depending on the presenter and on the audiences' prior knowledge of the material. It is recommended that the presentation be in the second format if time permits.
- 2) In this format time is allowed to attempt some of the sample problems during the presentation. This facilitates improved learning in several ways:
 - a) When students work sample problems together, the learning process becomes more active and students retain more of the information.
 - b) Many students do not ask questions (especially when there are people in the audience who are already working in the industry) because they fear appearing ignorant. Working out some of the sample problems among themselves allows students to question other participants without drawing attention to themselves.
 - c) Reinforcement of concepts immediately following the presentation of the material improves retention.

The time required for this type of presentation should be around two and one half to three and one half hours. The time can be increased or decreased by varying the number of sample questions attempted.

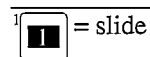

Preliminary Quiz

Have the students take three to four minutes to write answers to the following questions:

- 1) What is the difference between static and dynamic pressure?
- 2) What are the two ways pressure is created in a sprinkler system?
- 3) What causes pressure losses in a sprinkler system?

After the students have written their responses to the questions, ask for volunteers to give answers. At this point, be sure to give encouraging remarks to all who volunteer answers - even if the answer is incorrect. For instance if someone says, "Making a pipe smaller will increase pressure," you might respond that "while that is commonly perceived to be the case, in fact reducing pipe size will cause greater pressure losses." An instructor should use caution because if a student is embarrassed now, ALL the students will be offended and learning will be inhibited during the remainder of the session.

Answers:

- 1) Static pressure is a measurement of the pressure of water at rest; dynamic pressure is the measurement of water in motion.
- 2) Pressure is created in an irrigation system either by a drop in elevation (water going downhill) or by the use of a pump.
- 3) The major causes for pressure loss are the result of an increase in elevation (water going uphill) or of "friction" losses in pipe, fittings and valves. Minor losses include velocity head (the pressure required to generate movement of the water) and entrance losses as water enters a different size opening.

Table of Contents

Introduction	2
How Does Hydraulics Affect an Irrigation System	2
Important facts to learn	2
Water Pressure	3
How pressure is created by the weight of water	4
Important Facts	5
Does the shape or size of the container make a difference?	6
What does this mean in irrigation system design?	7
Static and dynamic pressure	8
Factors affecting static pressure	8
Sample problems: determining static pressure	10
Water Movement in Irrigation Systems	12
Factors Affecting Dynamic Pressure	12
Friction loss in pipe	12
Velocity	13
Inside diameter	13
Roughness	14
Length	15
Use of Pressure Loss Charts	16
What the charts are used for	18
Determining pressure loss in pipes with friction loss charts	18
Sample problems: using friction loss charts	19
Determining Dynamic Pressure Losses in Pipe	20
Sample problems: dynamic pressure	21
General Principles of Water Flow in an Irrigation System	23
Factors Affecting Flow in an Irrigation System	23
How the pressure available at the source affects flow	24
How pressure losses from the source to the outlet affect flow	25
Friction loss in pipe	26
Friction loss in fittings	26
Velocity head	26
Entrance loss	26
The relationship between pressure and flow	28
Increasing pressure at the source increases the flow	28
Using smaller pipe does not increase the flow	28
Using smaller pipe does not result in higher pressure	28
How the size of the outlet affects flow	29
What Happens When the Water Reaches a Sprinkler Head?	31
Flow and Pressure Loss in a Typical Sprinkler System	33
Sample problems: dynamic pressure losses in landscape irrigation systems	36
Pressure Loss in Fittings	40
Summary	40
Important Definitions	41
Answers to Sample Problems	42
Friction Loss Charts	46
Index	52

Introduction

Hydraulics is defined as a branch of science that deals with the effects of water or other liquids in motion. In this manual we will study characteristics of water both in motion and at rest. The emphasis will be on the relationships between flow, velocity and pressure. With this knowledge we will be able to determine pressure losses in pipe and fittings and pressures at various points in the irrigation system.

A knowledge of the basic principles of irrigation hydraulics is essential to designing and maintaining an economical and efficient irrigation system. Understanding the principles outlined in this manual will lead to irrigation systems that have a more uniform distribution of water and cost less to install and maintain.

3

How Does Hydraulics Affect an Irrigation System?

Water pressure in an irrigation system will affect the performance of the sprinklers. If the system is designed correctly there will be enough pressure throughout the system for all the sprinklers to operate properly. Maintaining this pressure in the system will help to ensure the most uniform coverage possible. While a consistent pressure is the primary goal, it is important to achieve this at the lowest cost. With a knowledge of hydraulics, it is possible to design a system using the smallest and therefore least expensive components while conserving sufficient pressure for optimum system performance.

4

Important facts to learn

- 1) The effect of static and dynamic pressure on sprinkler operation.
- 2) The forces that cause pressure to increase or decrease in an irrigation system.
- 3) The relationships between pressure, velocity and flow in an irrigation system.
- 4) How to calculate static and dynamic pressures at various points in an irrigation system.
- 5) How to determine dynamic pressure losses in pipe and fittings.

Water Pressure

5

Water pressure in irrigation systems is created in two ways: 1) by using the weight of water (such as with a water tower) to exert the force necessary to create pressure in the system or 2) by the use of a pump (a mechanical pressurization).

In many municipal water delivery systems both of these methods may be used to create the water pressure we have at our homes and businesses. Water tanks use gravity to create pressure. These tanks are located on a mountain top, tower or roof top. Because these storage tanks are located above the homes they serve, the weight of the water creates pressure in the pipes leading to those homes. In other cases, a “booster” pump is used to increase the pressure where the elevation of the water storage tank is not high enough above the home to provide sufficient pressure. In other areas, the water source may be a well, lake or canal with a pump generating the pressure.

We will discuss the effect of pumps on water pressure in another training manual, but in this manual we will explore how water pressure is affected by its weight and what happens to water pressure when water moves through irrigation pipes.

Water pressure can be measured or expressed in several ways:

6

- 1) psi; the most commonly used method in landscape irrigation, pounds of pressure exerted per square inch (psi),
- 2) feet of head; equivalent to the pressure at the bottom of a column of water 1 ft. high [in this case the unit of measurement is feet of head (ft./hd)].

7

How pressure is created by the weight of water

What water weighs at 60° F:

- 1 cubic foot (ft.³) or 1728 cubic inches (in.³) of water = 62.43 lb.
- 1 cubic inch, (in.³) of water = 0.0361 lbs.

Water creates pressure in landscape irrigation systems by the accumulated weight of the water.

In Fig. 1, we can see a container 1 ft. high and 1 ft. wide, holding 1 ft.³ of water, would create a column of water 1 ft. high over every square inch on the bottom of the container.

8

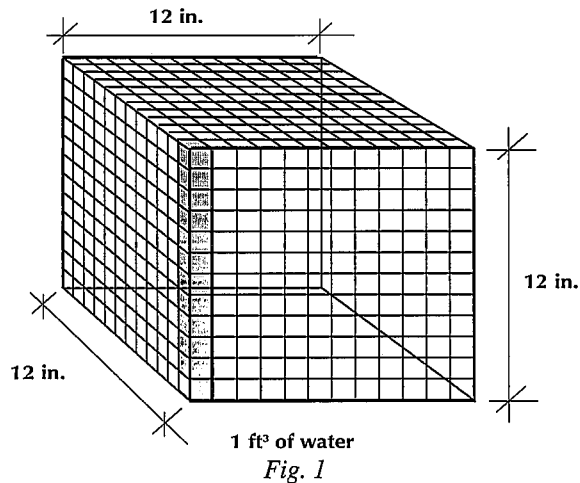

If we look at just one of those columns, Fig. 2, we can calculate the weight of water pressing on the bottom of the column in pounds per square inch (psi).

A column 12 in. high resting on a surface at the bottom of 1 in.² represents a column with 12 in.³ of water.

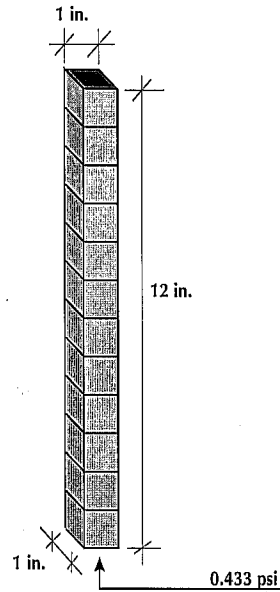

9

Fig. 2

The weight of the 12-in.-high column of water is 0.433 lbs. ($12 \text{ in.}^3 \times 0.0361 \text{ lbs. per in.}^3 = 0.433 \text{ lbs.}$). Therefore, a column of water 1 ft. high will exert a pressure at the bottom of 0.433 lbs. per in.² or 0.433 psi. This is a very **important number** because it means that as our column of water gets higher, **every 1 ft. of height added will increase the pressure at the bottom by 0.433 psi.**

For example, a column of water 2 ft. high creates a pressure at the bottom of 0.866 psi ($0.433 \text{ psi/ft.} \times 2 \text{ ft.} = 0.866 \text{ psi}$).

Important Facts

This gives us some important facts to remember. **Memorize these facts:**

- A column of water 1 ft. high = 1 foot of head = 0.433 psi.
- 1.0 psi equals the pressure created by a column of water 2.31 ft. high, or
1 psi = 2.31 ft. of head (ft./head).
- A column of water 1 ft. high creates 0.433 psi at the bottom, or
1 ft./head = 0.433 psi.

10

11

Does the shape or size of the container make a difference?

The shape or size of the container does **NOT** make any difference in the pressure at the bottom, as seen in Fig. 3. Because we are measuring the weight of water in a column resting on 1 in² regardless of the container's size or shape, pressure at **an equal depth** will be the same no matter what the shape or size of the container.

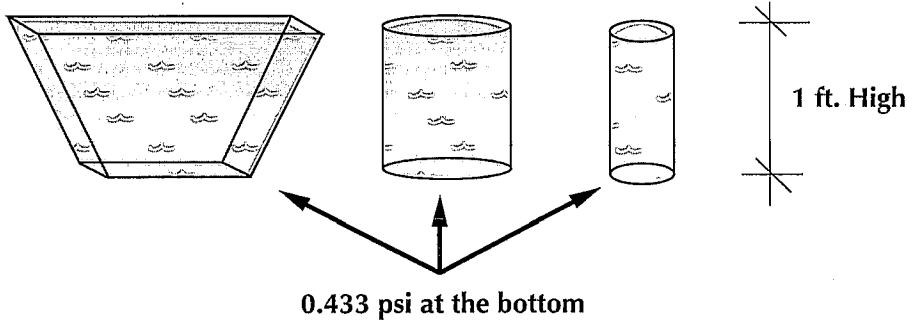
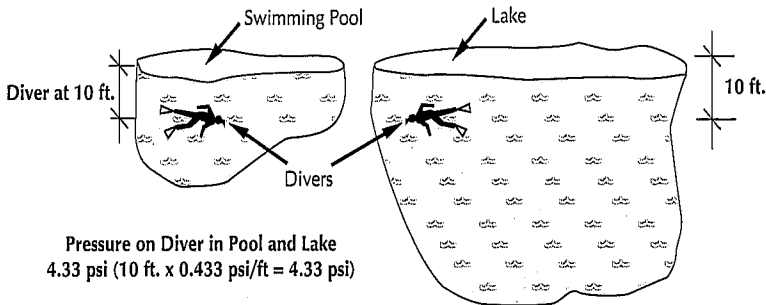

Fig. 3

While at first this does not seem possible, let's look at two examples that will help us to better understand this concept. First, consider the example of diving into a swimming pool or lake. When you dive below the surface of a lake or pool, the deeper you dive the more pressure builds up on your ears. The amount of increased pressure on your ears does not change with the shape of the pool nor does it change depending on whether you are diving into a backyard pool or a large lake. The pressure at any depth in that pool or lake is dependent upon the **height** of the column of water above that point - not on the shape or size of the pool.

12



The second example is that of a pipe in a tank of water.

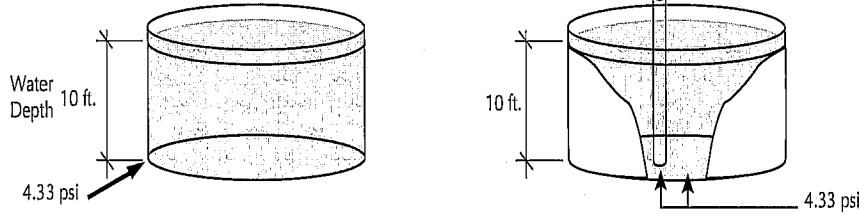

Fig. 4

In the diagram, Fig. 4, we can determine the pressure at the bottom of the tank to be 4.33 psi (0.433 psi/ft. of depth x 10 ft. water depth). If we lower a 10-ft.-long section of irrigation pipe (open on both ends) down into the tank, the pressure at the bottom of the pipe will be the same as that of the surrounding water, 4.33 psi. What may still be confusing about these concepts is that intuitively we know the TOTAL weight of the water in the pipe and in the larger tank is not the same - and that is true. However, we measure pressure as the force on **1 in.²** (pounds per square inch, psi) **not total weight.**

What does this mean in irrigation system design?

When designing landscape irrigation systems, **for every 1 ft. of elevation change there will be a corresponding change of pressure of 0.433 psi.**

13

14

Note to Instructors: At this point many in the audience may be lost but nobody will want to admit it. REQUIRE at least two questions be asked before moving on to more material. This will generally break the ice and get a couple of good questions quickly. Remember to praise those that are brave enough to ask; often times, simply a response of "Good Question" from the instructor will elicit still more questions.

15

Static and dynamic pressure

There are two classifications of water pressure:
static and dynamic¹ pressure:

- **Static pressure** is a measurement of water pressure when the **water is at rest**. In other words, the water is not moving in the system.
- **Dynamic pressure** is a measurement of water pressure with the **water in motion** (also known as working pressure).

Factors affecting static pressure

Static pressure is created either by elevation change or by a pump. Pumps are covered in another training manual so we will concentrate here on the effect of elevation change on static pressure. As previously discussed, each foot of elevation change results in a 0.433 psi change in pressure. As we can see in the following diagrams, the change in elevation that we are concerned with is the change in **vertical** elevation only, not in the length of pipe. Because water exerts pressure equally in all directions, the **length** of pipe will not affect the **static** pressure (it does affect the dynamic pressure, as we will see later).

If we return to our tank of water, Fig. 5, we can see that inserting a fourteen foot pipe into the tank of water at an angle does not affect the pressure at the bottom of the tank or pipe. **Static** pressure is not affected by the length of the pipe, only by elevation change.

16

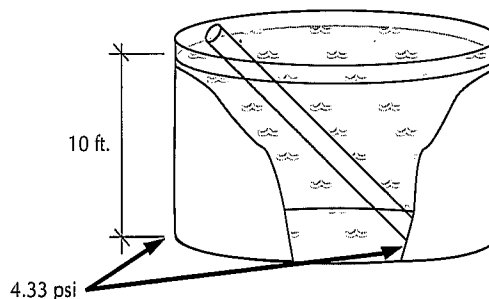

Fig. 5

¹ The term “working” pressure may be used instead of dynamic pressure.

We can see the effect of elevation change on static pressure in an irrigation system in Fig. 6 and 7. In the example in Fig. 6, the static pressure at the water meter is 60 psi. Since the control valve is below the water meter by 8 ft., the static pressure is increased by 3.46 psi. (8 ft. x 0.433 psi per foot = 3.46 psi).

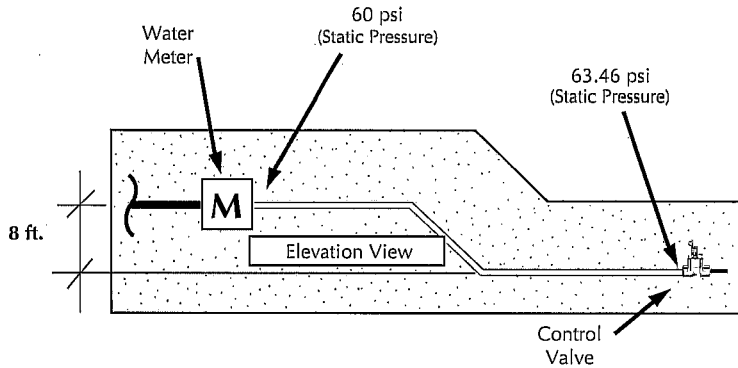
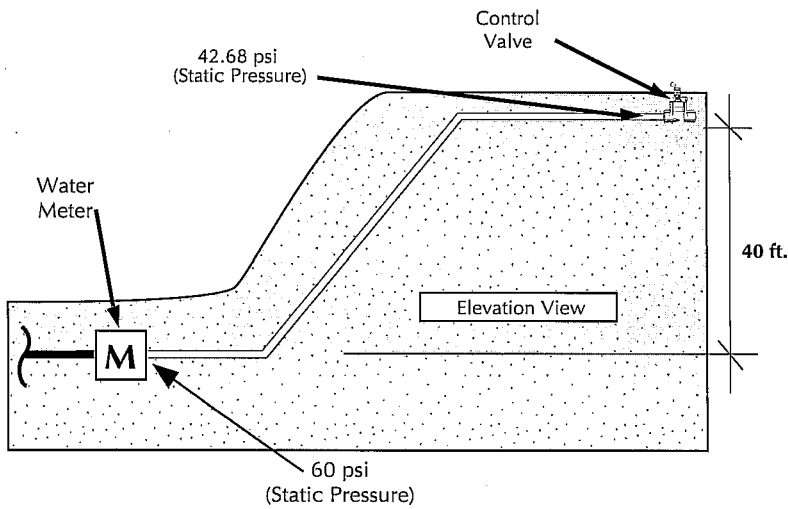

Fig. 6
 $8 \text{ ft.} \times 0.433 \text{ psi/ft.} = 3.46 \text{ psi}$
 $60 \text{ psi} + 3.46 \text{ psi} = 63.46 \text{ psi static pressure}$

Going uphill **reverses** the process: for every 1 ft. of vertical elevation gain the static pressure will drop by 0.433 psi.



The effect of elevation gain on static pressure
 Fig. 7

$40 \text{ ft.} \times 0.433 \text{ psi/ft.} = 17.32 \text{ psi}$
 $60 \text{ psi} - 17.32 \text{ psi} = 42.68 \text{ psi static pressure}$

Note to instructors: Be sure to emphasize that at this point we are only talking about STATIC pressure - not dynamic (working) pressure. Since some individuals will have some knowledge of hydraulics, you need to be sure they do not get confused about how pipe size, length and type affects dynamic pressure but not static pressure. Assure them we will be discussing dynamic pressure next.

Static pressure is not affected by the size or length of pipe. Both diagrams in Fig. 8 illustrate a control valve 40 ft. above a water meter. In the first case the main line from the meter to the valve is 100 ft. of two inch pipe and in the second it is 250 ft. of one inch pipe. The static pressure at each control valve is 42.68 psi. Only the **vertical elevation change** affects the static pressure.

19

Note to Instructors: in Fig. 8 the important points to make are:
 1.) elevation change is the only determinant in static pressure.
 2.) change in length of pipe or pipe size does **not** affect static pressure.

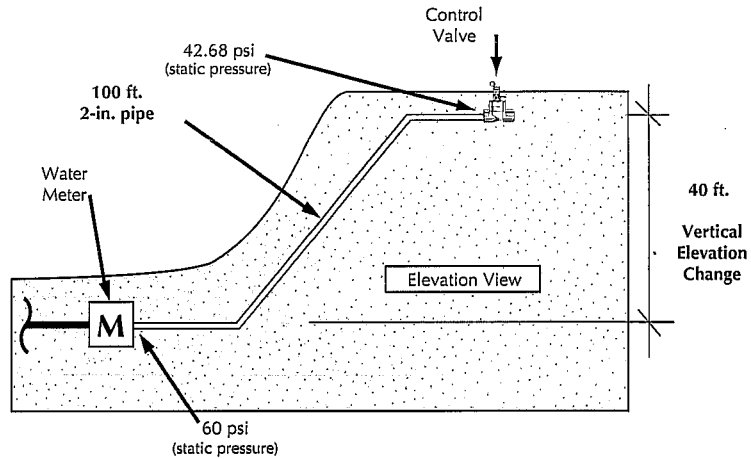

20

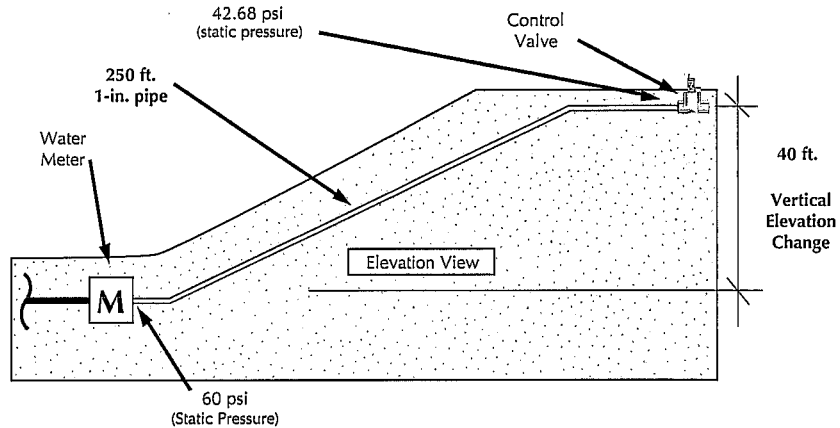

Vertical elevation change and static pressure
 Fig. 8

Note to Instructors: If sample problems are to be included in the presentation, it is recommended that students attempt nos. 2, 4 and 5. They should attempt one problem at a time with questions taken before moving on to the next problem. If the students do not have the manuals at the time of the presentation, the problems could be presented on a blackboard or overhead.

Sample problems: determining static pressure

(Answers are on p. 42)

1. For every foot of elevation change, the pressure in an irrigation system will change by _____ psi.
2. A change in elevation of 231 ft. will cause a change in pressure of _____ psi.

3. 256 ft. of head = _____ psi

4.

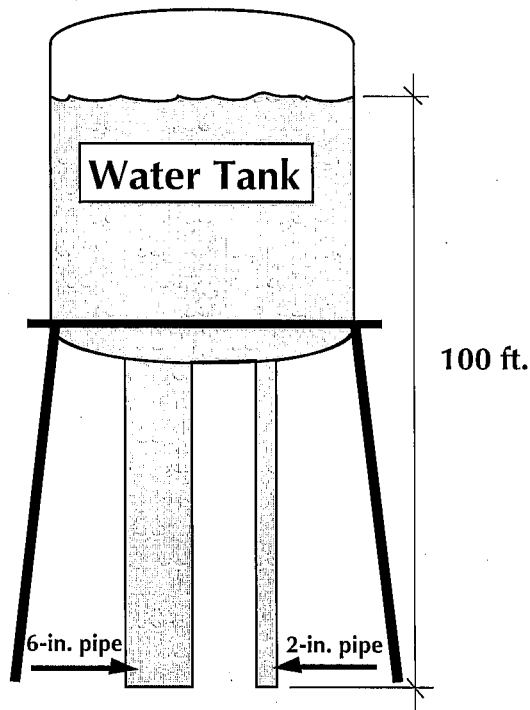

In the diagram above, what is the pressure at

A) the bottom of the 2-in. pipe? _____ psi

B) the bottom of the 6-in. pipe? _____ psi

5.

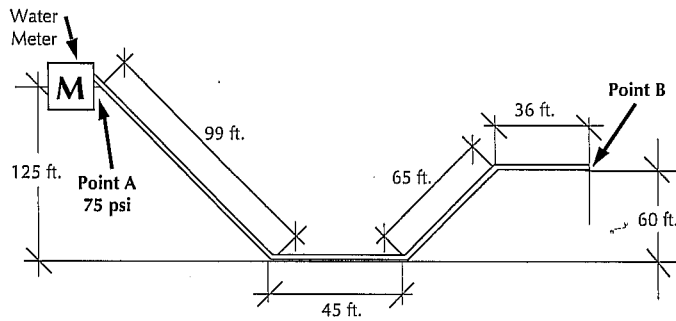

Elevation View

If the static pressure at the water meter discharge (point A) is 75 psi, the static pressure at point B would be _____ psi.

21

Water Movement in Irrigation Systems

When water moves through an irrigation system it is said to be in a dynamic state. The movement of water is described in terms of **velocity** (the speed at which it is moving) and **flow** (the amount of water moving through the system). The velocity is measured in feet per second (fps) and the flow is measured in gallons per minute (gpm). Dynamic water pressure is measured in the same units as static pressure (psi).

22

Factors Affecting Dynamic Pressure

So far we have discussed the factors that affect changes in static pressure. This section will explain factors that affect dynamic pressure.

Dynamic pressure is affected by the following factors:

- 1) change in elevation (change in elevation affects static and dynamic pressure in the same way)
- 2) friction losses in pipe, valves and fittings (pressure loss is caused by water moving through the system)
- 3) velocity head (the pressure required to make water move within the system; this is a minor loss and won't be calculated here)
- 4) entrance losses (the pressure lost as water flows through openings; this is also a minor loss and won't be calculated here)

Friction loss in pipe

23

When measuring dynamic pressure at any point in a landscape irrigation system, we must first determine the static pressure at that point and then subtract the pressure losses due to the movement of water.

As water moves through an irrigation system, pressure is lost because of turbulence created by the moving water. This turbulence can be created in pipes, valves or fittings. These pressure losses are referred to as "**friction losses.**"

There are four factors that affect friction losses in pipe:

- 1) the **velocity** of the water,
- 2) the **inside diameter** of the pipe,
- 3) the **roughness** of the inside of the pipe and
- 4) the **length** of the pipe.

1. **VELOCITY** is the speed at which water moves through the system and it is measured in **feet per second (fps)**. Water moving in the pipe causes turbulence and results in a loss of dynamic pressure. Increasing the velocity will cause increased turbulence and increased pressure losses. **In Fig. 9 the inside diameter, roughness and length remain the same.** However, due to increased velocity (fps), there is a greater dynamic pressure loss. [Note: With the increase in velocity there is a corresponding increase in flow (gpm). Velocity and flow are directly related. An increase or decrease in one will result in a corresponding increase or decrease in the other.]

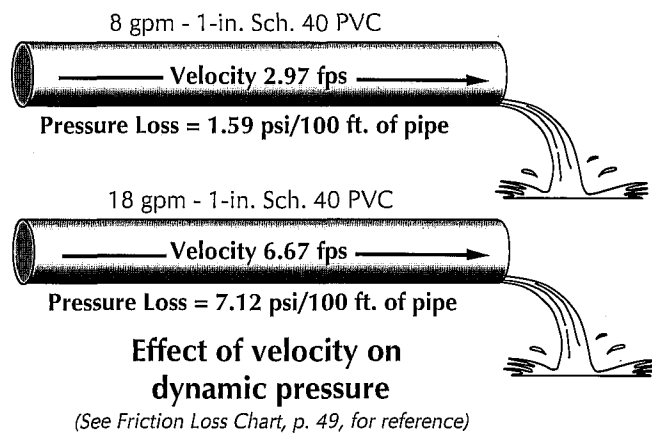

Fig. 9

When velocity increases, pressure loss increases. When the velocity is increased from 2.97 fps to 6.67 fps, the pressure lost in 100 ft. of pipe increases from 1.59 psi to 7.12 psi. The velocity typically increases when 1) the flow is increased, such as when additional sprinklers are added to an existing line or 2) a smaller pipe is used with the same flow (gpm).

2. **INSIDE DIAMETER** (i.d.) of the pipe: a smaller inside pipe diameter proportionally increases the amount of water in contact with the pipe surface. This increased contact **increases** the turbulence and consequently **increases** the dynamic pressure loss. In Fig. 10, the velocity, length and roughness remain the same but the inside pipe diameter is reduced. The reduced i.d. results in increased turbulence and reduced dynamic pressure. (Note: The velocity remains the same even though the pipe size is reduced because there is a corresponding reduction in the flow.)

Note to Instructors: In each example one factor varies while the other three remain constant, as in No. 1 where the diameter, roughness and length remain the same and the velocity is increased. This allows us to see the effects of increased velocity on pressure loss.

The fact that the flow also changes can be confusing to students. Explain that it is necessary to change the flow in order to have the velocity vary while keeping the pipe size the same.

In example No. 2 (inside diameter) the roughness, length and velocity remain the same while the only variable is the inside diameter. Students may question the fact that the flow and pipe type (Class 160 and Schedule 40 PVC) were changed. This was necessary in order to maintain the same velocity.

24

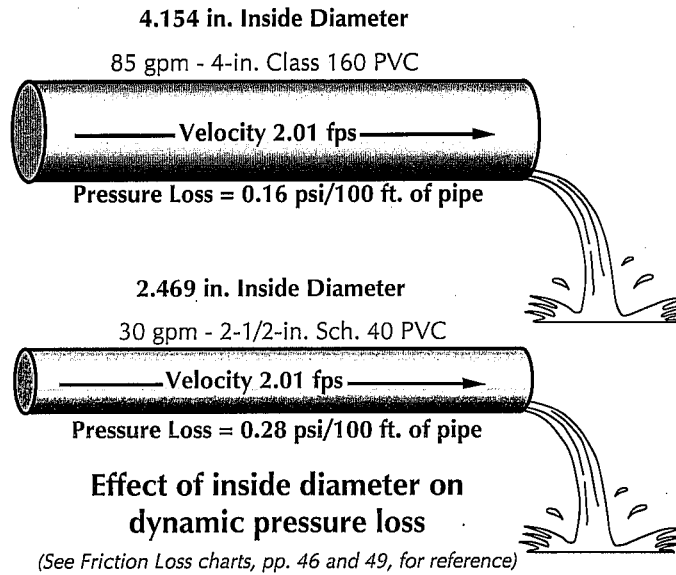

Fig. 10

Even with a smaller flow and the same velocity more turbulence was created in the small pipe because there was a greater percentage of the water in contact with the surface.

Note to Instructors: When comparing roughness, the inside diameters of 1-in. Schedule 40 PVC and 1-in. Schedule 40 Standard Steel pipe are the same. Therefore, the velocity also remains the same. Because we are comparing the same lengths of pipe, the only factor that changes is the roughness of the Standard Steel pipe compared to that of PVC pipe.

- ROUGHNESS** of the inside wall of the pipe is the third factor that affects friction loss in pipe. Pipe wall roughness is rated by a "C" factor. The lower the value of C, the rougher the inside wall of the pipe (in standard steel pipe C=100; in PVC pipe C=150.) The **rougher** the inside, the **more turbulence** created and the **greater** the pressure loss. In Fig. 11, the velocity, volume and inside diameter remain the same. As the roughness of the inside of the pipe increases (standard steel has a rougher pipe wall than PVC), there is an increase in turbulence, resulting in a greater pressure loss.

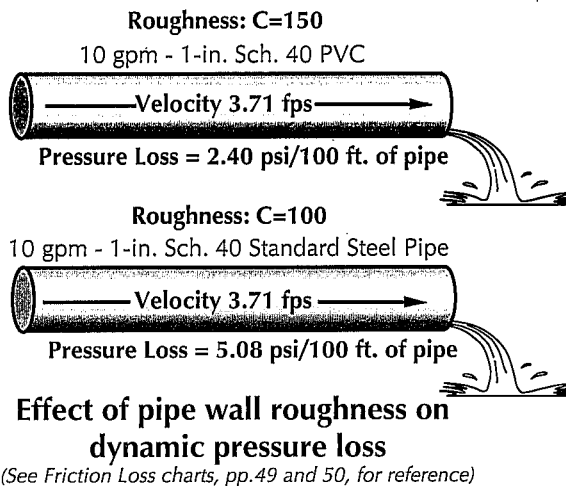

Fig. 11

4. **LENGTH** is the fourth factor affecting friction losses in pipe. The greater the distance, the greater the cumulative effect of the first three factors (velocity, i.d. and roughness). In Fig. 12 we see the direct relationship between increased length and increased pressure loss. The total pressure loss doubles as the length of the pipe doubles.

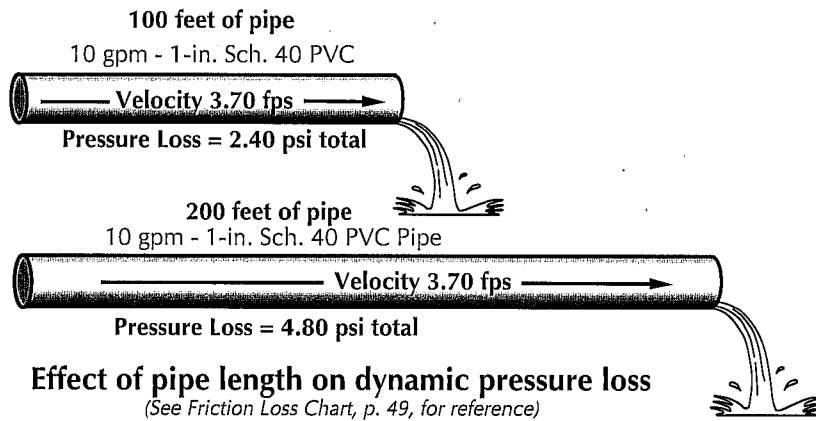

Fig. 12

These four factors affecting pressure loss in pipe were used to develop formulas² for calculating the pressure loss associated with various types of pipe. Several formulas were developed; the most common in landscape irrigation hydraulics is the **Hazen-Williams** formula. The Hazen-Williams formula can be represented as:

$$H_f = 0.090194 \left(\frac{100}{C} \right)^{1.852} \frac{Q^{1.852}}{d^{4.866}}$$

Where H_f = pressure loss in pounds per square inch (psi)

C = roughness factor

Q = flow in gallons per minute (gpm)

d = inside pipe diameter in inches

Since these formulas are somewhat cumbersome, we will rely on charts developed using the Hazen-Williams formula. Samples of these charts can be found on pages 46-51. The complete set is available in the "Hunter Industries Technical Manual."

Note to Instructors: In this comparison 1-in. Schedule 40 PVC is used for both pipes, so the inside diameter, velocity and roughness remain the same. The only variable is the length, which is twice as long in the bottom pipe.

27

² Crocker, King Pinping Handbook, Fifth Ed., McGraw Hill, 1967, pp. 3-179 to 3-181.

Use of Pressure Loss Charts

Figure 13 below represents a portion of one of the pressure loss charts found in the technical manual.

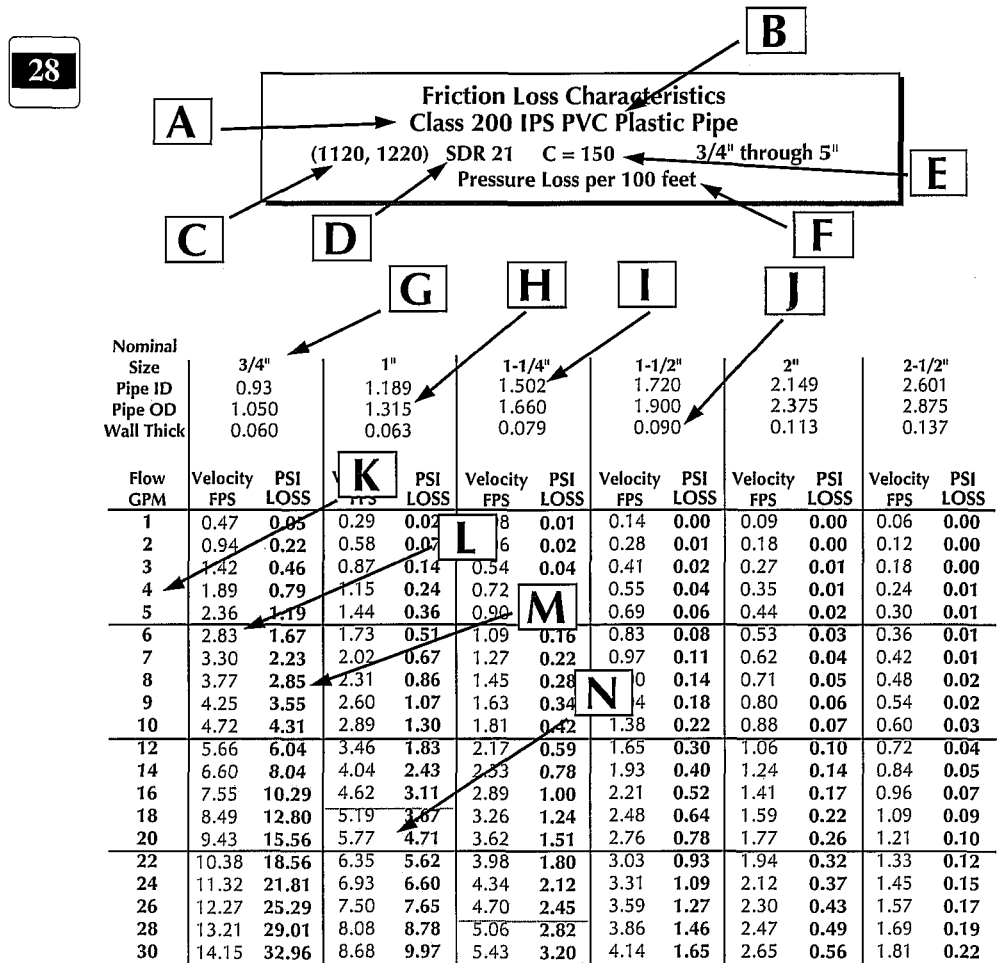

Fig. 13

The components of the typical friction loss chart are described below:

- A) Type of pipe represented in the chart.
- B) IPS - Iron Pipe Size - indicates that the pipe's outside diameter dimensions correspond to that of iron pipe. All IPS PVC pipe of the same nominal size will have the same outside diameter. For example: all 1/2-in. PVC irrigation pipe will have an outside diameter of 0.840 in.; thus all 1/2-in. slip fittings will fit on the outside of all types of 1/2-in. PVC pipe.
- C) (1120, 1220) - Represents a designation for the specifications of the plastic pipe.

- D) SDR – Standard Dimension Ratio – indicates the pipe’s wall thickness as a ratio of the outside diameter. Outside diameter of 1-in. pipe is 1.315 in. If you divide 1.315 by the SDR, 21, it will give you a minimum wall thickness.³
 Minimum wall thickness for 1-in. Class 200 PVC pipe $1.315/21=0.063$ in. Class-rated pipes (SDR pipes) maintain a uniform maximum operating pressure across all pipe sizes. This is not true of schedule rated pipes such as Schedule 40 PVC. In schedule rated pipes the maximum operating pressure decreases as pipe size increases. See the technical chart on “Pressure Ratings of Irrigation Pipe” in the Hunter Industries Technical Manual.
- E) C=150 – indicates the value of the C factor, which is a measure of the roughness of the inside of the pipe. The lower the number, the rougher the inside of the pipe and the greater the pressure loss. For PVC, C = 150; Galvanized Pipe C = 100.
- F) Designated pressure losses shown in the chart are per 100 ft. of pipe.
- G) Size – indicates the “nominal” pipe size. Nominal means “in name only,” and none of the actual pipe dimensions are exactly that size. For example, in the $3/4$ -in. pipe, none of the dimensions are actually $3/4$ -in.
- H) OD – outside pipe diameter in inches.
- I) ID – inside pipe diameter in inches.
- J) Wall Thick – wall thickness in inches.
- K) Flow (gpm) – flow rate in gallons per minute.
- L) Velocity (fps) – speed of water in feet per second at the corresponding flow rate.
- M) PSI Loss – pressure loss per 100 ft. of pipe in pounds per square inch at the corresponding flow rate.
- N) The shaded area on the chart designates those flow rates that exceed 5 fps. It is recommended that caution be used with flow rates above 5 fps in main lines where water hammer will be a concern.

³ There may be exceptions to this rule in the smallest pipe size of each class of pipe, as the minimum wall thickness allowed is 0.060 in. In these cases, either the wall thickness is rounded up to 0.060 in. (1-in. Class 160 PVC wall thickness is rounded up to 0.060 in.) or that pipe classification is not made in the smaller sizes (Class 200 PVC is not made in 1/2-in. size).

29

What the charts are used for

These charts are used to:

- Determine the pressure loss in pipe due to friction losses
- Determine the velocity at various flow rates
- Use pressure losses and/or velocities to determine appropriate pipe sizes (pipe sizing is covered in another training manual)

30

Determining pressure loss in pipes with friction loss charts

Using the Friction Loss Chart for Class 315 PVC on page 48:

- 1) Find the flow of water in gallons per minute (gpm) in the column on the left.
- 2) Read across to the right to the column for psi loss corresponding to the specific pipe size.
- 3) Divide this number by 100 to find the psi loss per foot.
- 4) Multiply this number times the length of the pipe in feet.

Example No. 1: Determine the pressure lost in 175 ft. of 1-in. Class 315 PVC pipe with a flow of 10 gal. per min. (gpm).

- psi loss per 100 ft. = 1.74 (from the chart)
- $1.74 \text{ psi loss per } 100 \text{ ft.} / 100 = 0.0174 \text{ psi loss}$
(psi loss per 100 ft. divided by 100 to find psi loss per foot)
- $0.0174 \text{ psi loss per foot} \times 175 \text{ ft.} = 3.05 \text{ psi}$
- 3.05 psi loss in 175 ft. of 1-in. Class 315 PVC at 10 gpm.

Example No. 2: Determine the maximum flow allowed in a 1-in. Class 315 PVC pipe without allowing the velocity to exceed 5 ft. per sec. (fps).

- Find the velocity column for 1-in. Class 315 PVC and read down the column until you find the velocity closest to (but not exceeding) 5 fps.
- This should be 4.87 fps. Now read across to the left hand column to find the flow at that velocity (15 gpm).
- The most water you can put through a 1-in. Class 315 PVC pipe without exceeding 5 fps is 15 gpm.

Sample problems: Using friction loss charts (answers are on p. 42)

Note to Instructors: If sample problems are to be included in the presentation, it is recommended that students attempt Nos. 1, 3, 4 and 7.

Using the chart on page 48 for Friction Loss Characteristics in PVC Class 315 IPS Plastic Pipe, answer the following questions:

- 1) What is the pressure loss in 100 ft. of 1/2-in. Class 315 PVC at 6 gpm?
- 2) What is the pressure loss in 100 ft. of 3/4-in. Class 315 PVC at 6 gpm?
- 3) What is the pressure loss in 50 ft. of 1-in. Class 315 PVC at 12 gpm?
- 4) What is the pressure loss in 780 ft. of 1-1/2-in. Class 315 PVC at 20 gpm?
- 5) What is the pressure loss in 0.5 ft. of 1-in. Class 315 PVC at 12 gpm?
- 6) What is the maximum amount of water that can flow through 100 feet of 1-in. Class 315 PVC pipe and not lose more than 1.0 psi?
- 7) What is the maximum amount of water that can flow through a 3/4-in. Class 315 PVC pipe and not exceed 5 fps?

Determining Dynamic Pressure Losses in Pipe

When calculating dynamic pressures we use the following factors:

- A) Pressure change due to elevation change.⁴
- B) Pressure loss due to friction losses in the pipe (based on the factors mentioned on p. 12).
- C) Pressure losses in valves, meters, etc. (These losses are determined by the manufacturer and listed in product literature or technical charts.)
- D) Pressure losses due to fittings.
(See p. 40 for additional information.)

The following example illustrates how the dynamic pressure at a given point in a landscape irrigation system is determined. Pressure change due to the change in elevation is calculated and the friction losses are subtracted from the sub-total. The example and the following sample problems use the Friction Loss Charts at the back of the manual.

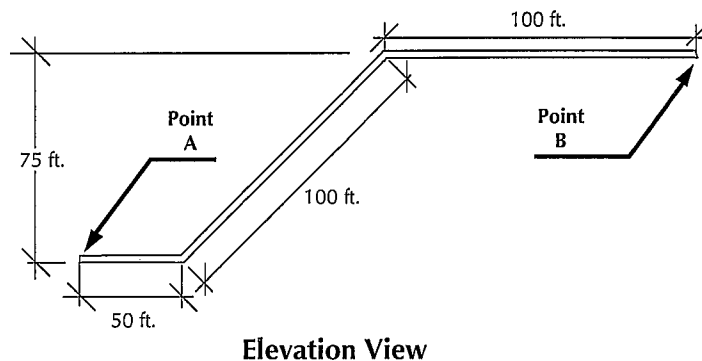

Fig. 14

In Fig. 14, all the pipe is 1-1/4-in. Class 200 PVC and the flow is 18 gpm from point A to point B. At point A a pressure gauge reading indicates 85 psi. In order to determine the dynamic pressure at point B, first find the pressure change due to change in elevation and then combine that with the friction loss in the pipe.

⁴ Elevation change affects both static and dynamic pressure in the same way.

Pressure loss due to the higher elevation at point B (an elevation gain):

34

$75 \text{ ft.} \times 0.433 \text{ psi per ft. of elevation change} = 32.48 \text{ psi less at point B}$

Pressure loss due to friction in the pipe:

Use the friction loss charts at the back of the manual to find the pressure loss at 18 gpm in 1-1/4-in. Class 200 PVC pipe: friction loss from the chart is 1.24 psi per 100 ft.

psi loss in pipe:

$(50 \text{ ft.} + 100 \text{ ft.} + 100 \text{ ft.}) \times (1.24 \text{ psi loss per } 100 \text{ ft.} \div 100 \text{ ft.}) = \text{psi loss}$

Note: the 1.24 psi loss from the charts is psi loss per 100 ft. and is divided by 100 to find the pressure loss per foot, $(1.24 \div 100 = 0.0124)$.

35

psi loss in pipe = $250 \text{ ft.} \times 0.0124 \text{ psi loss per ft.}$

psi loss in pipe = 3.10 psi [total due to friction loss]

85.00	psi pressure at point A
<u>- 32.48</u>	psi due to elevation change
52.52	psi subtotal at point B
<u>- 3.10</u>	psi due to friction loss in pipe from point A to point B
49.42	psi dynamic pressure at point B

36

Sample problems: dynamic pressure (answers are on p. 43)

Note to Instructors: If sample problems are to be included in the presentation, we recommend that students attempt Nos. 1 and 3.

- 1) In the diagram below, if the dynamic pressure at point A is 70 psi, what would the dynamic pressure be at point B (no elevation change)?

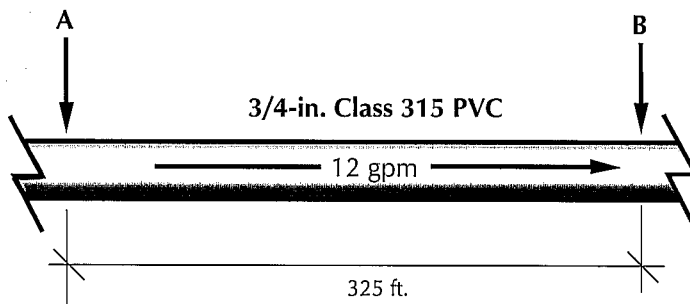

- 2) In the diagram below, the length of pipe from point A to point B is 125 ft. What is the dynamic pressure at point B if the dynamic pressure at point A is 85 psi?

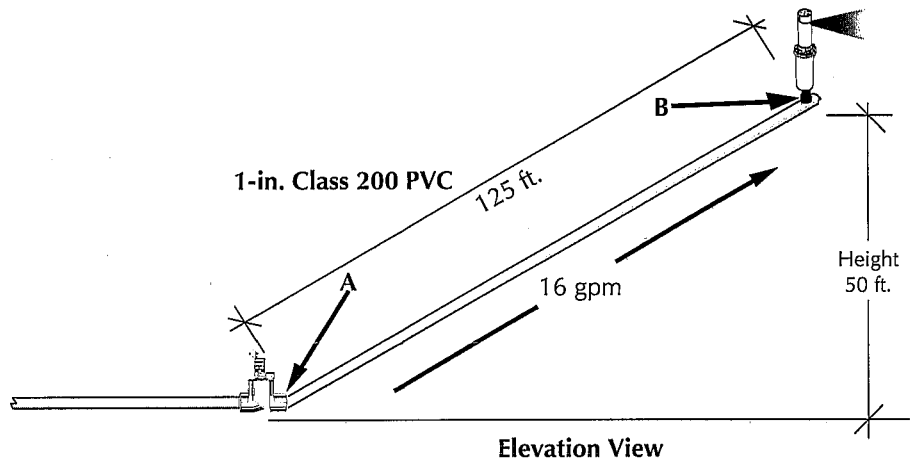

- 3) In the diagram below, the pipe is 1-in. Class 315 PVC and the flow 12 gpm. If the dynamic pressure at point A is 45 psi, what is the dynamic pressure at point B?

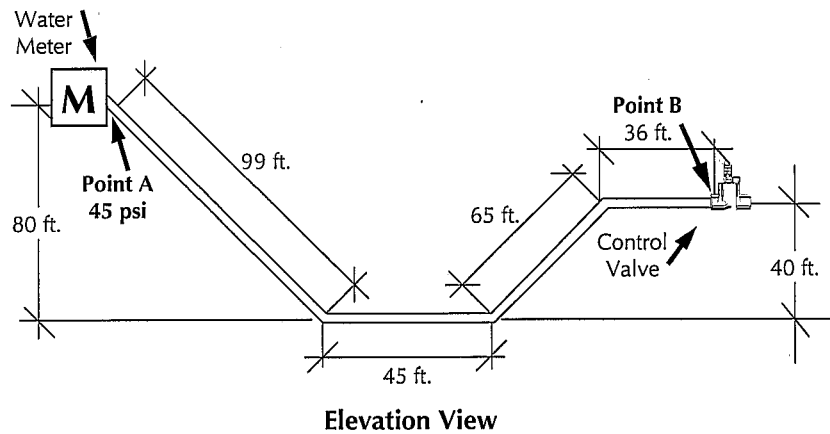

General Principles of Water Flow in an Irrigation System

37

Water in an irrigation system has energy called pressure. The pressure may be created by the weight of a column of water, as discussed in the section on Static Pressure, or the pressure may be created by a pump. As water flows through an irrigation system all of the energy or pressure that is available at the source is expended. Some of the pressure is expended as friction losses in pipes, valves and fittings and some is used to create velocity and flow. The flow and velocity will increase until all the pressure available at the source is consumed as friction losses or used to create velocity. For example, an irrigation system with 50 psi at the source will expend **all 50 psi** between the source and the point where the water has left the system (an open pipe or sprinkler nozzle). **The quantity (gpm) and velocity (fps) will increase until the cumulative pressure losses, from the source to the outlet, equal the pressure available at the source.**

In other words, every pound of increased pressure at the water source will cause more water to flow through the outlet. As the flow increases so does the velocity resulting in increased pressure losses. These increased pressure losses will equal the increase in pressure at the source.

Factors Affecting Flow in an Irrigation System

The flow in an irrigation system is determined by three factors:

- 1) the **pressure (psi) available at the source** (p. 24)
- 2) the **pressure losses from the source to the outlet(s)**, (p. 25) and
- 3) the **size and number of outlets** (p. 29)

In our examples we start with a tank filled with water. It is 115.5 ft. from the water surface to the tank outlet. The water pressure created at the tank outlet is 50 psi ($0.433 \times 115.5 = 50$).

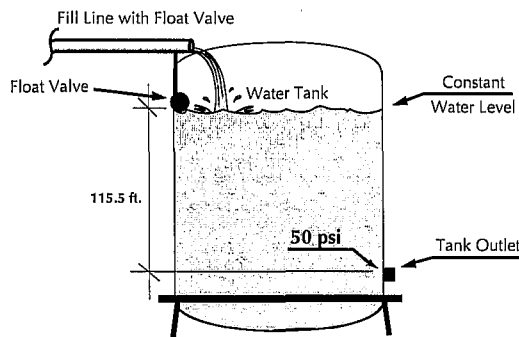

Fig. 15

38

Note to Instructors: In the following series of diagrams a float valve is shown below the fill pipe. This is included in the drawing to represent a realistic way to maintain a uniform water level. It functions by opening the fill pipe whenever the water drops below the 115.5-ft. depth. The only exception is shown in Fig. 17, where the water supply has been shut off and the water level has been allowed to drop to 46.19 ft.

39

How the pressure available at the source affects flow

The 50 psi at the tank outlet, shown in Fig. 16, is created by a water tank full to 115.5 ft. above the tank outlet (115.5 ft. x 0.433 psi per ft. = 50 psi). In the first example, we have opened a fill-line and used a float valve to maintain a constant water level allowing water from the fill-line to replace water leaving through the tank outlet.

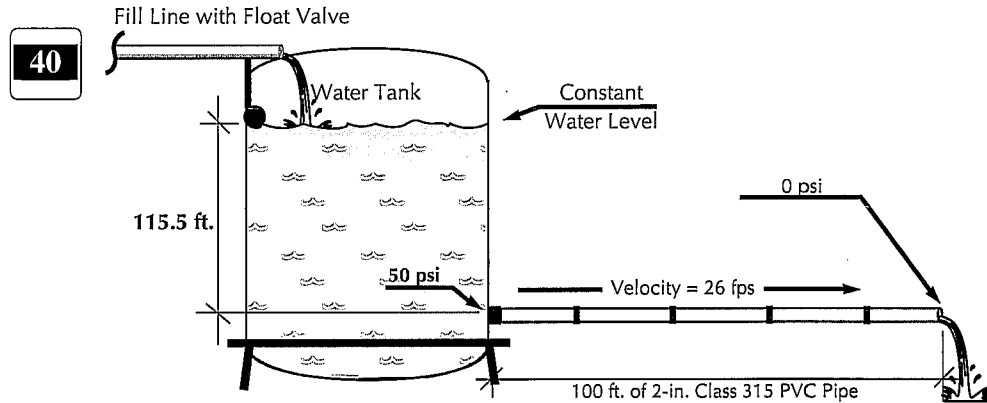

Fig. 16

With the 2-in. Class 315 PVC discharge line wide open (unrestricted flow), the water velocity (fps) increases until all of the available pressure is lost to friction in the pipe, fittings or other losses. The increased velocity creates increased pressure losses until the pressure losses equal the pressure available at the source. Under these conditions the velocity is 26 fps and the flow is 260 gpm. This is greater than the velocities and pressure losses listed in friction loss charts. Mathematical formulae were used to calculate the velocity and flow.

Now where did that pressure go? One of the most difficult concepts to understand is how water that has left a pipe, like the one in the diagram above, no longer has any pressure. Remember, the water velocity in the pipe will increase until all the pressure available at the source is consumed. Consider the water leaving the "fill line" at the top of the tank. As this water leaves the pipe and flows into the top of the tank, it is no longer under pressure.

Another example is water from a hose that flows out onto the ground. The water velocity in the hose increases until all the pressure available at the source has been consumed. When the water flows out onto the ground, it is no longer under pressure.

No one should design an irrigation system with the velocity and flow this high; therefore, 26 fps and 260 gpm are not even listed on the normal pressure loss/velocity charts and were calculated by formula instead. As we will see later, the flow and velocity are kept to much lower levels by regulating the number of sprinklers on a pipe or valve, which, in turn, regulates the flow.

Next we look at what happens when the water pressure at the source drops. In Fig. 17, the fill-line has been shut off and the water level in the tank allowed to drop. When the level in the tank has dropped to a depth of 46.19 ft. above the tank outlet the pressure at the outlet is 20 psi ($46.19 \times .433 = 20$ psi). As might be imagined, the flow through the pipe outlet has been reduced. With the pressure at 20 psi, the discharge is approximately 160 gpm at a velocity of 16 fps. **The drop in flow resulted from the drop in pressure at the source.**

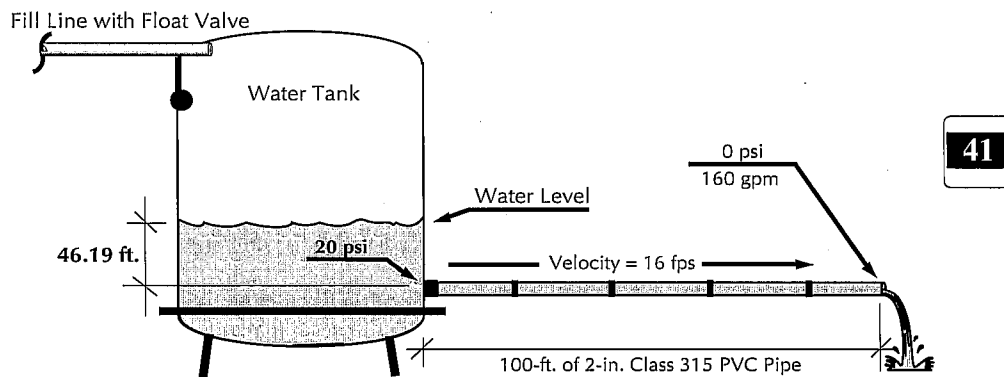

Fig. 17

A pressurized irrigation system will dissipate all the pressure at the source by the time the water leaves the discharge point. As shown in Figs. 16 and 17, the water velocity and flow increase in the pipe until the total pressure losses incurred, from the tank to the pipe outlet, equal the pressure available at the source.

Pressure at the source directly affects the velocity and flow in an irrigation system. At 20 psi at the source, the velocity is 16 fps and the flow is 160 gpm. If the tank is filled back to 115.5 ft., the flow increases until there is a total of 50 psi in pressure losses from the source to the discharge (260 gpm at 26 fps).

How pressure losses from the source to the outlet affect flow

In Fig. 18, there is a constant pressure at the source of 50 psi and an unrestricted flow through 100 ft. of 2-in. Class 315 PVC pipe. Under these conditions, the amount of water that will flow through the pipe is approximately 260 gpm at 26 fps.

With 50 psi at the source, the flow of water through the pipe increases until it reaches 26 fps. At 26 fps pressure losses from the inlet of the pipe to the outlet equal the pressure available at the source. Fig. 18, and the table below show how and where the 50 psi at the source is lost.

42

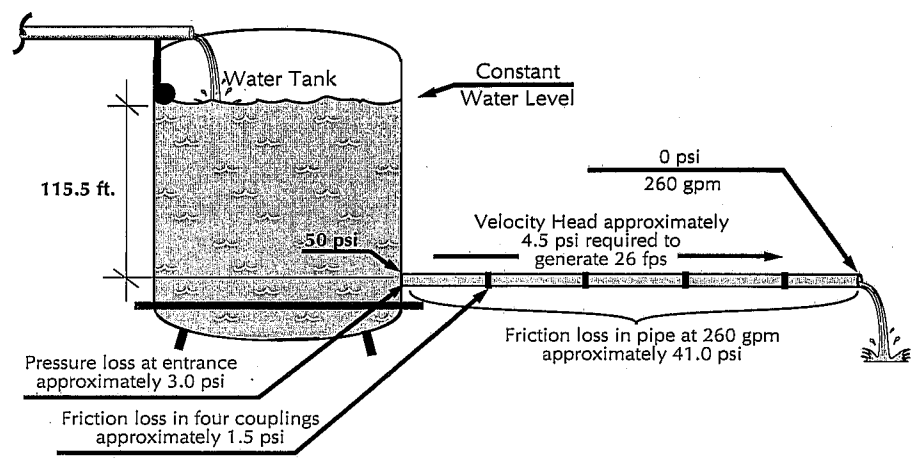

Fig. 18

43

Friction loss in pipe – At 26 fps through a 2-in. Class 315 PVC pipe (this is above the velocities and pressure losses listed in the pressure loss charts and was computed using the mathematical formulæ for pressure losses in pipe):

Approximately **41.0 psi** loss

Friction loss in fittings – Pressure lost in the four couplings (PVC pipe is made in 20-ft. sections requiring four couplings to assemble 100 ft. of pipe):

Approximately **1.5 psi** loss

Velocity head – This is the pressure required to generate 26 fps (amount of pressure required to move the water through the pipe at 26 fps):

Approximately **4.5 psi** loss

Entrance losses – Pressure lost as the water enters the pipe

Approximately **3.0 psi** loss

Total pressure lost or consumed: **50 psi**

Note:

- Friction loss calculations made with the Hazen-Williams formula (see p. 15).
- Friction loss in couplings estimated to be 0.9 equivalent foot each.
- Velocity head calculated as equal to $\left(\frac{V^2}{2g}\right) 0.433$ (calculated per Irrigation, Fifth Ed., p. 240).
- Entrance losses calculated as equal to $0.5 \left(\frac{V^2}{2g}\right) 0.433$ (calculated as a function of velocity as per Irrigation, Fifth Ed., p. 241).

If there is an increase in pressure (psi) at the source, the rate of flow (gpm) and velocity (fps) will also increase. When the flow and velocity are increased, the pressure losses from friction, velocity head and entrance losses also increase. The rate of flow increases until all the additional pressure is used to create a higher flow (gpm) and velocity (fps). In our examples, the flow at 20 psi is approximately 160 gpm. If the pressure is increased by 30 psi, from 20 to 50 psi at the source, the flow will increase by 100 gpm from approximately 160 gpm to 260 gpm. The increase of 100 gpm in the flow will increase pressure losses by 30 psi, so that by the time the water has left the pipe, all the pressure available at the source will have been used.

Note to Instructors: At this point there will be some students who do not feel comfortable with the fact that there is no pressure after the water leaves the pipe. While this point is explained later in the manual, you may want to address it here. The pressure (energy) that was available at the start of the pipe has been used to create the velocity, or consumed as friction losses.

Some Practical Examples:

A) **The laminar flow drip emitter:** If the pipe is small enough and long enough, the pressure loss will be so great that the water will just drip out. This is how some drip emitters work. Long, small water pathways (like pipes) inside the emitters cause so much pressure loss that very little velocity or flow remain at the discharge point.

B) **Nozzle size controls flow:** In a sprinkler system, the water flow is less than that from an open-ended pipe. Flow is controlled by limiting the number of sprinklers per control valve and the size of the sprinkler nozzles. The nozzles are smaller than the open pipe. The smaller nozzles control the flow of water in the system. Because of the reduced flow and velocity there is reduced pressure loss from the water source to the sprinkler head. The increased pressure available at the sprinkler is expended as the water escapes through the small nozzle. At the nozzle, the water velocity increases as it exits at the nozzle, and this increased velocity dissipates the remaining pressure. This increased velocity throws the water up to a hundred feet or more, depending on the sprinkler design.

C) **The “thumb on the hose” trick:** Turn on a long hose and the water barely comes out. If you put your thumb over the end of the hose and allow just a tiny amount of water to flow past your thumb, you have reduced the velocity and flow through the hose, which results in less pressure loss. The pressure you have conserved is now converted to a higher velocity as the water flows past your thumb. The higher velocity will cause the water to be thrown farther than before. This sometimes leaves a person with the impression that a smaller pipe increases pressure. In reality, the reduced flow results in more pressure remaining at the end of the hose, which in turn creates more velocity as the water leaves the hose.

The relationship between pressure and flow

Figure 19, charts the relationship between pressure at the source and flow. This relationship is shown for three sizes of PVC pipe. There are three points that should be noted about this chart.

- 1) **Increasing pressure at the source increases the flow.** On the chart the two bold dashed lines indicate the increase in flow from 160 gpm to 260 gpm as the pressure at the source is increased from 20 psi to 50 psi.
- 2) **Using smaller pipe does not increase the flow.** Smaller pipe sizes have less flow at any given pressure. Since decreasing pipe size does not increase the pressure at the source, the result of decreasing pipe size is to reduce the flow (gpm).
- 3) **Using smaller pipe does not result in higher pressure.** Smaller pipe leads to greater pressure loss. For example, on the chart, a flow of 20 gpm in our 1-in. pipe would require a pressure at the source of about 9 psi. In order to maintain the same 20 gpm flow in the smaller 1/2-in. pipe, we would need over 50 psi at the source. Smaller pipe results in greater pressure loss, not higher pressure.

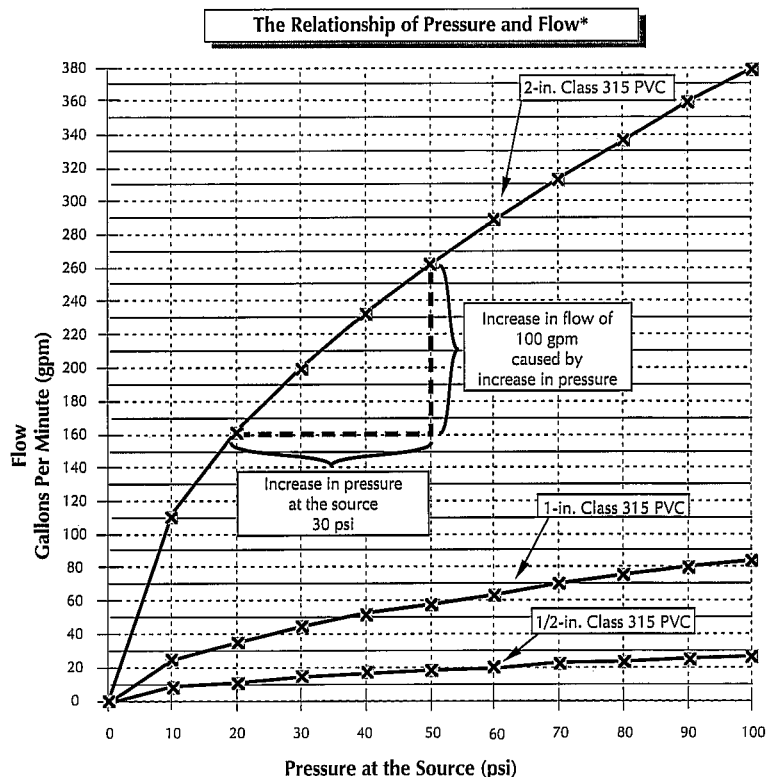

* Approximate flow through an unrestricted 100-ft.-long section of pipe with four couplings. Pressure losses include: friction loss in pipe and couplings, velocity head and entrance losses. Exit losses not included.

Fig. 19

How the size of the outlet affects flow.

At first it would seem that any 100-ft.-long section of 2-in. class 315 PVC pipe with 50 psi at the source should have a flow of 260 gpm. However, it must be remembered that the size of the outlet at the discharge end of the pipe will also affect the flow of water.

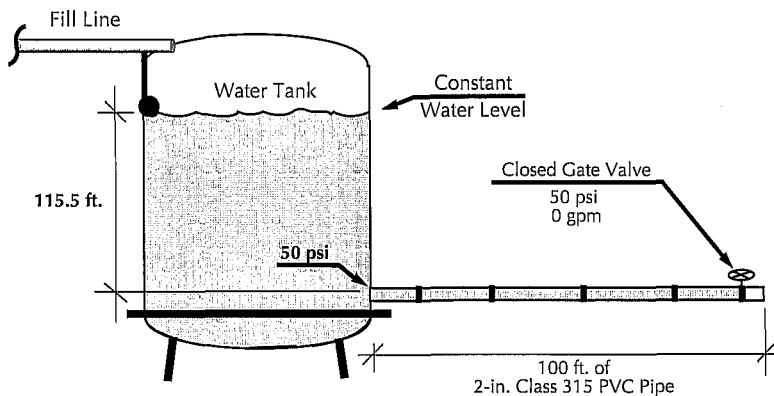

Fig. 20

Figure 20 is the most extreme example of this principle; the pipe has a closed gate valve that completely stops the flow. Even though the pipe is still the same size and has the same pressure at the source, there is NO flow.

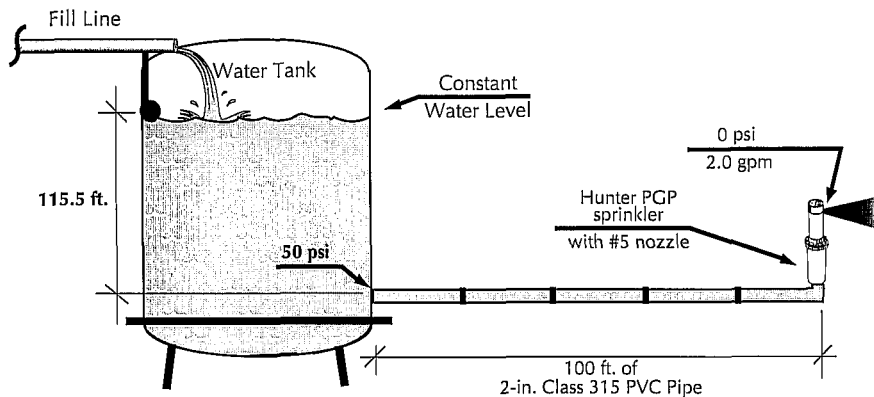

Fig. 21

In Fig. 21, we have replaced the gate valve with a Hunter PGP sprinkler with a #5 Nozzle. Because the outlet is so much smaller than the pipe, with 50 psi at the source, it will allow a flow of only 2.0 gpm⁵.

⁵ Pressure loss in 100 ft. of 2-in. Class 315 PVC at 2.0 gpm is less than 0.1 psi; therefore performance of the PGP sprinkler is based on 50 psi.

Note: The diagram indicates 0 psi at the outlet of the nozzle, yet if we place a pressure gauge, with a Pitot tube⁶, into the stream of water leaving the sprinkler nozzle, it will indicate water pressure. This is because the energy (pressure) remaining when the water reaches the sprinkler is converted to velocity. The pressure remaining when the water reaches the sprinkler is still nearly 50 psi and the nozzle outlet is small. This pressure at the sprinkler is used to create a high velocity as the water flows through the nozzle. When the water is stopped by the pressure gauge, the velocity is converted back to pressure. When the sprinkler is operating the energy contained in the water's high velocity is dissipated as the water pushes through the air. As the velocity is reduced the water falls to the ground.

Note to Instructors: Once again, students may have come to a point where they are confused. If you feel the students are not asking sufficient questions or may not fully understand what has just been presented, ask for questions again. Instead of requiring questions this time, you may want to ask for questions and wait a full seven seconds. Most audiences will be comfortable enough at this point to ask a question in that amount of time (seven seconds of silence is a long time). If no one asks a question, either they know the material well enough or you may have to resort to demanding additional questions. Because understanding this portion of the material is critical to understanding the hydraulics, be sure you do not leave students behind at this point.

48

As shown in the previous examples, the flow in an irrigation system is controlled by:

- 1) The **pressure (psi) available at the source**. Increasing the pressure at the source will increase the flow in the system by making more pressure available to compensate for pressure losses in the system.
- 2) The **pressure losses from the source to the outlet(s)**. Reducing pipe size or any other factor which causes a greater pressure loss will result in reduced flow.
- 3) The **size or number of the outlet(s)**. Changing the size or number of outlets, such as changing the size of the sprinkler nozzles or the number of sprinklers on a line will change the amount of flow.

⁶ A Pitot tube is a device that consists of a tube having a short right-angled bend which is placed into a stream of water with the mouth of the bent part directed upstream and is used with a pressure gauge.

What Happens When the Water Reaches a Sprinkler Head?

It is important to see how hydraulic principles apply to a landscape irrigation system. To better understand how a typical system works, let's look at a sprinkler system that has four sprinklers using 10 gpm each for a total of 40 gpm. The system has 30 psi at the control valve and has been installed as shown in Fig. 22.

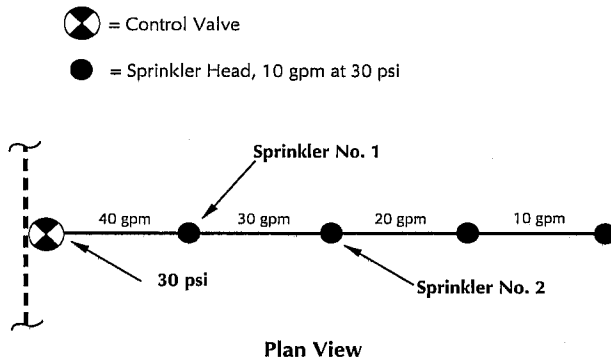

Fig. 22

When the system is in operation, 10 gpm flows from each sprinkler head. The pressure at each sprinkler remains relatively constant because the pipe and fittings have been sized to minimize pressure loss. For the sake of this example we will assume a negligible pressure loss so that each sprinkler is operating at 30 psi. Later we will examine the pressure losses between each head.

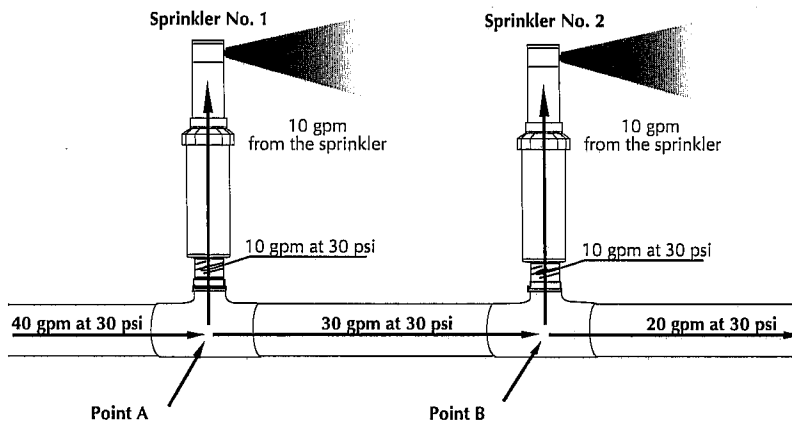

Fig. 23
(Sprinklers Nos. 1 & 2 from Fig. 22)

At point A (below sprinkler No. 1) the flow of water splits, with 10 gpm flowing up and out of sprinkler No. 1 and 30 gpm flowing on to sprinkler No. 2. The pressure, however, does not split. Instead, the pressure is equal in both directions at point A. At point B the flow of water splits in the same way it did at point A with 10 gpm

49

50

Note to Instructors: It is important to remember that for our purposes in this example we are assuming that there are no pressure losses between the sprinkler heads; therefore, the flow from each head is 10 gpm. In reality, there would be minor pressure losses and each head would have a slight variation in flow. Some students may pose the question about why there is no pressure loss. If this happens, explain that for our purposes we have assumed no pressure loss because what we are trying to show is how the flow of water splits while the pressure does not.

flowing to the sprinkler and 20 gpm flowing toward sprinklers farther down the line. Once again, the pressure does not split. The pressure at point B (below sprinkler No. 2) is 30 psi both at the base of the sprinkler as well as in the direction of the sprinklers downstream.

Because this is a difficult concept to understand, Fig. 24 shows a variation on the same principle.

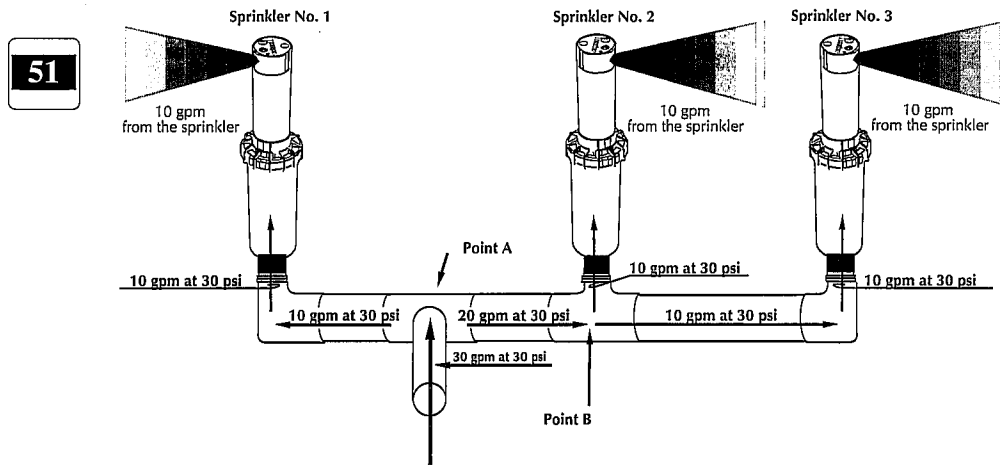

Fig. 24

Note to Instructors: The concept of the water flow splitting while the pressure remains equal in both directions is difficult for students to grasp. Be sure at this point to take time to clarify this point. This would be a good time to REQUIRE at least two questions before proceeding.

In this example, 30 gpm enters the horizontal pipe at point A at 30 psi. Ten gallons per minute then flow to sprinkler No. 1 and 20 gpm flow toward sprinklers No. 2 and No. 3. The pressure, however, at point A is pushing the water equally in both directions with 30 psi. The volume splits but the pressure pushes equally in both directions.

The same situation occurs at point B where the water pressure is 30 psi pushing toward sprinkler No. 2 and 30 psi pushing toward sprinkler No. 3. In this case the 20 gpm splits, with 10 gpm going to sprinkler No. 2 and 10 gpm going on to sprinkler No. 3. The flow of water splits at each of these points but the pressure is pushing equally in each direction.

Flow and Pressure Loss in a Typical Sprinkler System

In the previous section we assumed each sprinkler was operating at exactly the same pressure. In reality there are some pressure losses in the pipe between each head. In this section we will see how to calculate those pressure losses that occur between sprinklers to determine if our system will operate properly.

Fig. 25 illustrates a system with four sprinklers controlled by one valve. While there is some loss of pressure between the sprinklers, we will still assume they are delivering 6.0 gpm.

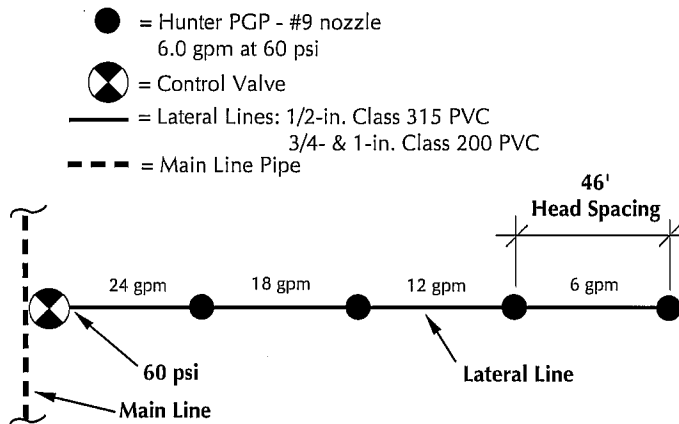

Plan View

Fig. 25

In order to maintain a relatively uniform pressure throughout the system, the lateral line pipe has been sized as shown in Fig. 26. (Pipe sizing is covered in another education module, but for clarification, pipe is downsized when volume is reduced because smaller pipe and fittings are less expensive.)

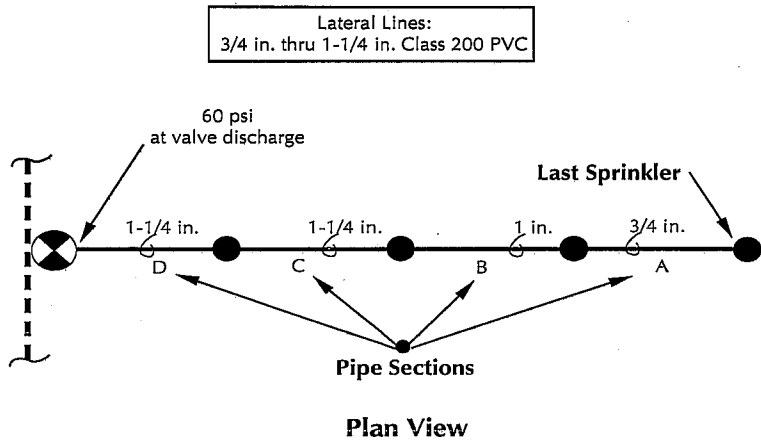

Fig. 26

As water flows through our sprinkler system, the pressure losses due to friction and the other factors **reduce the pressure available at the sprinklers**. Each sprinkler on the line has less pressure than the one before it (assuming the system is not running down a slope). It is important to maintain relatively uniform pressures for all sprinklers on a given control valve because sprinkler performance (gpm and radius of throw) will vary as the pressure at each sprinkler varies. Our design goal is to have all sprinklers controlled by one valve within +/- 10% of the pressure at which they were designed to operate.

In our sample problem, according to the sprinkler manufacturer's specifications, the sprinklers have been designed to operate at 60 psi. This means that +/- 10% of the designed operating pressure is an operating range of 54 – 66 psi. Since we have 60 psi at the discharge of the valve, we must check to be sure that we have at least 54 psi (a 10% variation) at the last head (Note: If the pipe were running down a slope, you would want to be sure you did not have more than 66 psi). We can check to see if we have sufficient pressure at the last sprinkler by determining the pressure loss through each section of pipe. The following table, Fig. 27, will aid in these calculations.

(Note: Even though we know there is a slight drop in pressure at each succeeding sprinkler, resulting in a slightly lower gpm, for the sake of simplifying the calculations we will still use 6 gpm for the flow from each sprinkler.)

Pipe Section	Type	Size	gpm	Length	psi loss/100 ft. ⁷	Actual psi Loss ⁸
A	Cl. 200	3/4 in.	6	46 ft.	1.67	0.77
B	Cl. 200	1 in.	12	46 ft.	1.83	0.84
C	Cl. 200	1-1/4 in.	18	46 ft.	1.24	0.57
D	Cl. 200	1-1/4 in.	24	46 ft.	2.12	0.98
Total psi loss in pipe from the valve to the last head						3.16 psi
Pressure at the valve discharge						60.00 psi
Pressure loss in pipe from valve to last head						-3.16 psi
Estimated pressure loss in fittings (10% of pipe loss) ⁹						-0.32 psi
Pressure remaining at the last head						56.52 psi

Pressure Loss Calculations

Fig. 27

The preceding example illustrates the pressure losses in pipe. By performing this calculation we can check to see if we have designed our system to maintain a sprinkler pressure at each head within 10% of the pressure at which the head was designed to operate. This is important because it assures us the system will operate properly before it is installed. This type of calculation would not have to be performed for every valve on a project, just for the valve most likely to have the lowest pressure (the “worst-case” scenario).

The following are sample problems for pressure loss calculations.

55

Note to Instructors: the example calculates pressure loss in pipe and estimates the pressure loss in fittings from the control valve to the last head. When determining total pressure loss from the water source to the last head, pressure losses through valves, backflow prevention devices, main line pipe, additional fittings and elevation changes would have to be calculated.

56

⁷ Refer to the class 200 PVC Friction Loss chart on pg. 47.

⁸ Refer to p. 20 for more information on calculating actual pressure loss in pipe.

⁹ Refer to p. 40 for more information on pressure loss in fittings.

Note to Instructors: If sample problems are to be included in the presentation, it is recommended that students attempt Nos. 1 and 3.

Sample problems: dynamic pressure losses in landscape irrigation systems

(Answers are on p. 44 & 45)

57

1) Determine the dynamic pressure at the “worst-case sprinkler” in the diagram by filling in the table below. (Use the pressure loss charts at the back of this manual.)

● = Hunter “PS” Type - Model 15F
4.0 gpm at 35 psi

⊗ = Control Valve

— = Lateral Lines: 1/2-in. Class 315 PVC
3/4-in. and 1-in. Class 200 PVC

- - - = Main Line Pipe

Note: To reduce crowding, two diagrams have been used to show gpm, pipe size and head spacing.

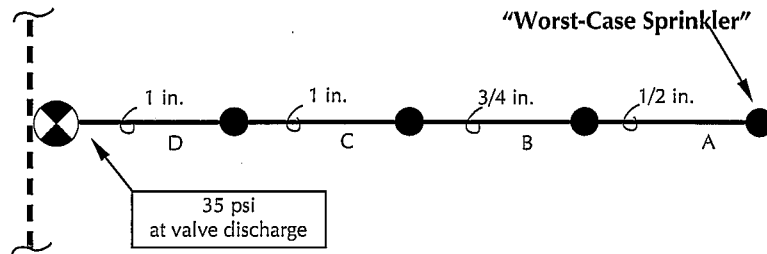

Note to Instructors: Slide 58 on pg. 44, shows the answer to this problem.

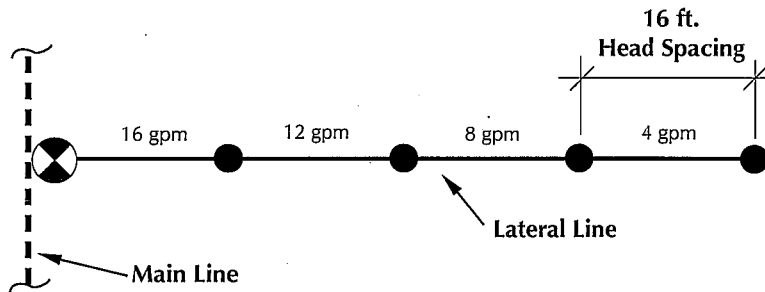

Pipe Section	Type	Size	gpm	Length	psi Loss/100 ft.	Actual psi Loss
A	_____	_____	_____	_____	_____	_____
B	_____	_____	_____	_____	_____	_____
C	_____	_____	_____	_____	_____	_____
D	_____	_____	_____	_____	_____	_____

Total psi loss in pipe from the valve to the last head _____

Pressure at the valve discharge _____ psi

Pressure loss in pipe from valve to last head _____ psi

Estimated pressure loss in fittings (10% of pipe loss) _____ psi

Pressure remaining at last head _____ psi

2) Determine the dynamic pressure at the “worst-case sprinkler” in the diagram by filling in the table below. (Use the pressure loss charts at the back of this manual.)

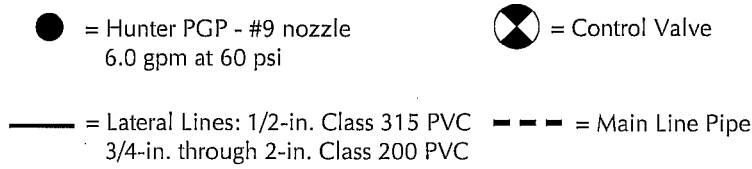

Note: To reduce crowding, two diagrams have been used to show gpm, pipe size and head spacing.

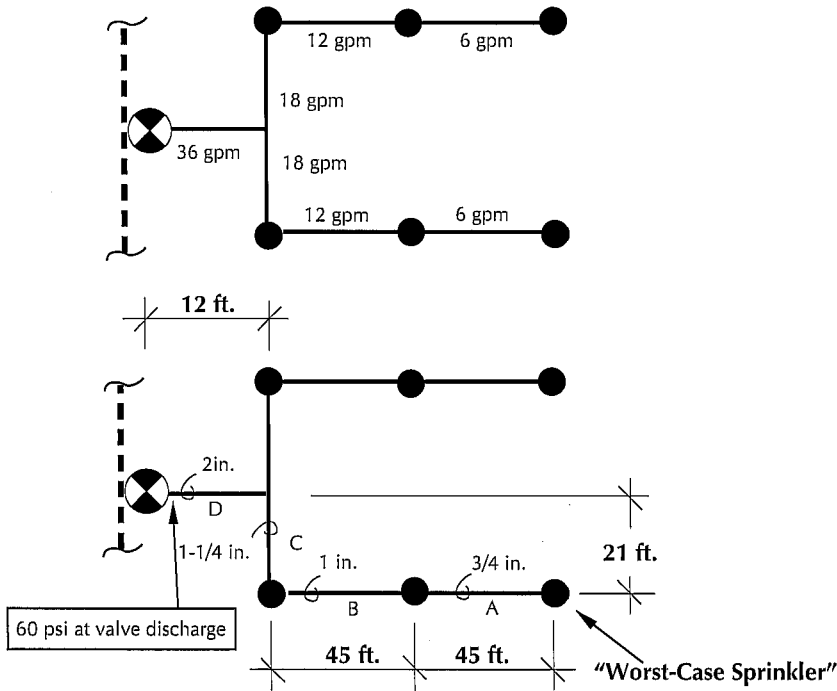

Pipe Section	Type	Size	gpm	Length	psi Loss/100 ft.	Actual psi Loss
A	_____	_____	_____	_____	_____	_____
B	_____	_____	_____	_____	_____	_____
C	_____	_____	_____	_____	_____	_____
D	_____	_____	_____	_____	_____	_____

Total psi loss in pipe from the valve to the last head _____

Pressure at the valve discharge _____ psi

Pressure loss in pipe from valve to last head _____ psi

Estimated pressure loss in fittings (10% of pipe loss) _____ psi

Pressure remaining at last head _____ psi

3) Determine the dynamic pressure at the “worst-case sprinkler” in the diagram by filling in the table below. (Use the pressure loss charts at the back of this manual.)

- = Hunter “1-20” - #9 Nozzle
6.0 gpm at 60 psi
- ⊗ = Control Valve
- = Lateral Lines: 1/2-in. Class 315 PVC, 3/4 in. and larger Class 200 PVC
- - - = Main Line Pipe

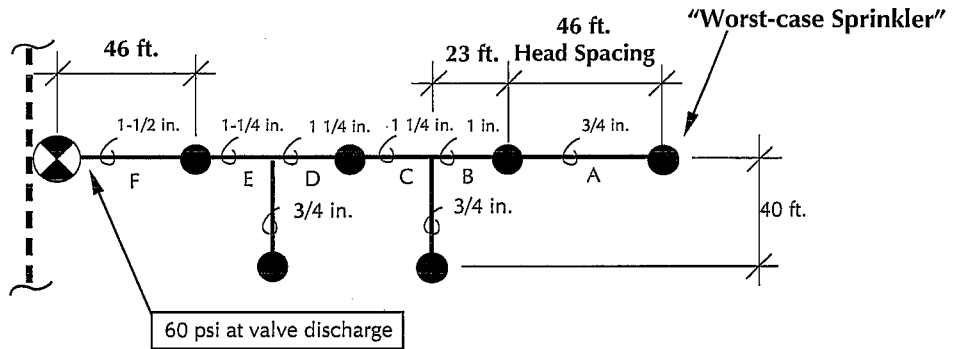

Pipe Section	Type	Size	gpm	Length	psi Loss/100 ft.	Actual psi Loss
A	_____	_____	_____	_____	_____	_____
B	_____	_____	_____	_____	_____	_____
C	_____	_____	_____	_____	_____	_____
D	_____	_____	_____	_____	_____	_____
E	_____	_____	_____	_____	_____	_____
F	_____	_____	_____	_____	_____	_____

Total psi loss in pipe from the valve to the last head _____

Pressure at the valve discharge _____ psi

Pressure loss in pipe from valve to last head _____ psi

Estimated pressure loss in fittings (10% of pipe loss) _____ psi

Pressure remaining at last head _____ psi

4) Determine the dynamic pressure at the “worst-case sprinkler” in the diagram by filling in the table below. In this example the lateral line pipe used is polyethylene (PE or Poly pipe). (Use the pressure loss chart at the back of this manual)

- = Hunter “I-10” – #5 nozzle
2.0 gpm at 50 psi
- ⊗ = Control Valve
- = Lateral Lines: Polyethylene Tube SDR Pressure Rated
- - - = Main Line Pipe

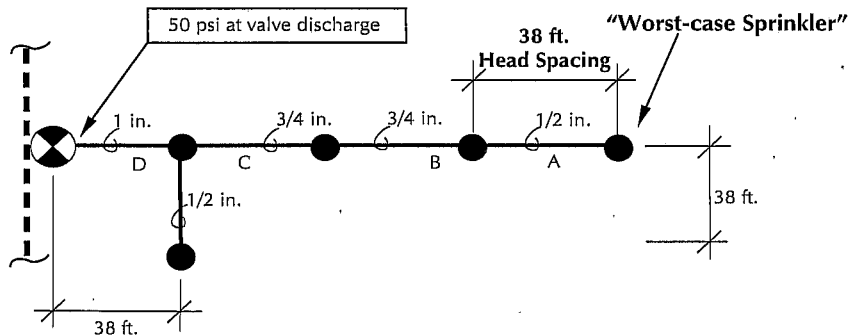

Pipe Section	Type	Size	gpm	Length	psi Loss/100 ft.	Actual psi Loss
A	_____	_____	_____	_____	_____	_____
B	_____	_____	_____	_____	_____	_____
C	_____	_____	_____	_____	_____	_____
D	_____	_____	_____	_____	_____	_____
Total psi loss in pipe from the valve to the last head						_____
Pressure at the valve discharge						_____ psi
Pressure loss in pipe from valve to last head						_____ psi
Estimated pressure loss in fittings (10% of pipe loss)						_____ psi
Pressure remaining at last head						_____ psi

61

Pressure Loss in Fittings

While more accurate pressure losses can be determined, irrigation designers often estimate the pressure loss in fittings as a percentage of the pressure lost in the pipe. For example, if a section of pipe from the control valve to the worst case sprinkler had a friction loss of 4.0 psi the pressure loss in the fittings would be estimated at 10 – 20% of the pressure loss in the pipe, depending on the system design. In our examples an estimate of 10% is deemed reasonable. Pressure losses of 25% or more may occur in systems with a large number of 90° elbows and/or heads spaced closer together, as might be the case in irregular-shaped planters around apartments or condos.

62

Summary

63

The design of a landscape irrigation system requires an understanding of hydraulics. Changes in elevation and friction losses in pipe, valves and fittings affect pressure, which in turn affects sprinkler performance. Irrigation hydraulics is used to determine the volume of

64

water available for use by the system, the pressure available at the sprinkler heads and the correct pipe sizes. Irrigation designers who understand hydraulics can design systems that are more efficient and cost less.

Important Definitions

- 1) **Static Pressure** – The pressure of water at rest.
unit of measure = pounds per square inch (psi)
Static pressure is affected by elevation change or by the force of a pump. For each 1 ft. of elevation change, static pressure (or dynamic pressure) changes by 0.433 psi.
- 2) **Dynamic Pressure** – The pressure of water in motion.
Dynamic pressure is affected by changes in pressure caused by either elevation change or a pump, as well as by friction losses in pipe, valves and fittings.
unit of measure = pounds per square inch (psi)
- 3) **Velocity** – The speed at which water is moving.
unit of measure = feet per second (fps)
- 4) **Flow** – The quantity of water moving through the system. Flow is affected by: (a) the pressure available at the source, (b) the pressure losses from the source to the outlet or outlets, and (c) the size or number of outlet(s).
unit of measure = gallons per minute (gpm)
- 5) **Friction Loss** – A term used to identify pressure losses caused by water turbulence. Friction loss is affected by: (a) velocity, (b) pipe inside diameter, (c) roughness of the inside of the pipe, and (d) length of the pipe.
unit of measure = pounds per square inch per 100 ft. of pipe (psi/100 ft.)
- 6) **Velocity Head** – The amount of pressure required to generate a specific velocity. This is the amount of energy or pressure that is used to make the water move at a given velocity.
unit of measure = psi or feet of head (ft./head)

Answers to Sample Problems

Static Pressure - p. 10

- 1) 0.433 psi
- 2) $231 \text{ ft.} \times 0.433 \text{ psi per ft.} = 100.02 \text{ psi}$
- 3) One foot of head is equal to the pressure created by a column of water 1 ft. high.
 $256 \text{ ft.} \times 0.433 \text{ psi per ft.} = 110.85 \text{ psi}$
- 4) A) 43.3 psi
B) 43.3 psi
The pressure is the same in both pipes because it is determined by the height of the column of water above that point regardless of the diameter of the pipe.
- 5) 103.15 psi
Since we are measuring static pressure, the length of pipe does not affect the pressure loss; the only factor is the elevation change which is multiplied by 0.433 psi per ft.
 - $125 \text{ ft.} - 60 \text{ ft.} = 65 \text{ ft.}$ elevation change to point B - downhill
 - $65 \text{ ft.} \times 0.433 \text{ psi} = 28.15 \text{ psi}$ increase
 - $75 \text{ psi} + 28.15 \text{ psi} = 103.15 \text{ psi}$

Using Friction Loss Charts - p. 19

- 1) 5.97 psi
- 2) 2.03 psi
- 3) 1.22 psi
- 4) 8.19 psi
- 5) 0.01 psi
- 6) 7 gpm
- 7) 9 gpm

Dynamic Pressure Losses in Pipe - p. 21

1) psi loss in pipe = 7.32 psi loss per 100 ft. x 325 ft.

psi loss in pipe = 0.0732 per ft. x 325 ft.

psi loss in pipe = 23.79 psi

70.00 psi pressure at point A

- 23.79 psi due to friction loss in pipe

46.21 psi dynamic pressure at point B

2) psi loss due to elevation gain = 0.433 psi per ft. x 50 ft.

psi loss due to elevation gain = 21.65 psi

psi loss in pipe = ~~4.15~~ ^{3.11 psi} psi loss per 100 ft. x 125 ft. per 100

psi loss in pipe = ~~0.0415~~ per ft. x 125 ft. ~~0.0311~~ ^{0.0311} per ft. x 125 ft.

psi loss in pipe = ~~5.19~~ psi ^{3.89} psi

85.00 psi pressure at point A

- 21.65 psi due to elevation gain

63.35 psi subtotal at point B

- 3.89 psi due to friction loss in pipe

59.46 psi dynamic pressure at point B

3) psi gain due to elevation change = 0.433 psi per ft. x (80 ft. - 40 ft.)

psi gain due to elevation change = 0.433 psi per ft. x 40 ft.

psi gain due to elevation change = 17.32 psi

psi loss in pipe = 2.43 psi loss per 100 ft. x (99 ft. + 45 ft. + 65 ft. + 36 ft.)

psi loss in pipe = 0.0243 per ft. x 245 ft.

psi loss in pipe = 5.95 psi

45.00 psi pressure at point A

+17.32 psi due to elevation change

62.32 psi subtotal at point B

-5.95 psi due to friction loss in pipe

56.37 psi dynamic pressure at point B

Dynamic Pressure Losses in Irrigation Systems - pg. 36

1)

Pipe Section	Type	Size	gpm	Length	psi loss/100 ft.	Actual psi loss
A	CL. 315	1/2 in.	4	16 ft.	2.82	0.45
B	CL. 200	3/4 in.	8	16 ft.	2.85	0.46
C	CL. 200	1 in.	12	16 ft.	1.83	0.29
D	CL. 200	1 in.	16	16 ft.	3.11	0.50
Total psi loss in pipe from the valve to the last head						1.70 psi
Pressure at the valve discharge						35.00 psi
Pressure loss in pipe from valve to last head						-1.70 psi
Estimated pressure loss in fittings (10% of pipe loss)						-0.17 psi
Pressure remaining at last head						33.13 psi

2)

Pipe Section	Type	Size	gpm	Length	psi loss/100 ft.	Actual psi loss
A	CL. 200	3/4 in.	6	45 ft.	1.67	0.75
B	CL. 200	1 in.	12	45 ft.	1.83	0.82
C	CL. 200	1-1/4 in.	18	21 ft.	1.24	0.26
D	CL. 200	2 in.	36	12 ft.	0.78	0.09
Total psi loss in pipe from the valve to the last head						1.92 psi
Pressure at the valve discharge						60.00 psi
Pressure loss in pipe from valve to last head						-1.92 psi
Estimated pressure loss in fittings (10% of pipe loss)						-0.19 psi
Pressure remaining at last head						57.89 psi

3)

60

<u>Pipe Section</u>	<u>Type</u>	<u>Size</u>	<u>gpm</u>	<u>Length</u>	<u>psi loss/100 ft.</u>	<u>Actual psi loss</u>
A	CL. 200	3/4 in.	6.0	46 ft.	1.67	0.77
B	CL. 200	1 in.	12.0	23 ft.	1.83	0.42
C	CL. 200	1-1/4 in.	18.0	23 ft.	1.24	0.29
D	CL. 200	1-1/4 in.	24.0	23 ft.	2.12	0.49
E	CL. 200	1-1/4 in.	30.0	23 ft.	3.20	0.74
F	CL. 200	1-1/2 in.	36.0	46 ft.	2.32	1.07
Total psi loss in pipe from the valve to the last head						3.78 psi
Pressure at the valve discharge						60.00 psi
Pressure loss in pipe from valve to last head						-3.78 psi
Estimated pressure loss in fittings (10% of pipe loss)						-0.38 psi
Pressure remaining at last head						55.84 psi

4)

<u>Pipe Section</u>	<u>Type</u>	<u>Size</u>	<u>gpm</u>	<u>Length</u>	<u>psi loss/100 ft.</u>	<u>Actual psi loss</u>
A	SDR-PE	1/2 in.	2.0	38 ft.	1.76	0.67
B	SDR-PE	3/4 in.	4.0	38 ft.	1.62	0.62
C	SDR-PE	3/4 in.	6.0	38 ft.	3.43	1.30
D	SDR-PE	1 in.	10.0	38 ft.	2.73	1.04
Total PSI loss in pipe from the valve to the last head						3.63 psi
Pressure at the valve discharge						50.00 psi
Pressure loss in pipe from valve to last head						-3.63 psi
Estimated pressure loss in fittings (10% of pipe loss)						-0.36 psi
Pressure remaining at last head						46.01 psi

Friction Loss Characteristics Class 160 IPS PVC Plastic Pipe

(1120,1220) C=150 SDR 26

PSI Loss Per 100 Feet of Pipe Sizes 1" thru 5"

Nominal Size Pipe ID Pipe OD Wall Thick	1"		1-1/4"		1-1/2"		2"		2-1/2"		3"		4"		5"		Nominal Size Pipe ID Pipe OD Wall Thick
	1.195 1.315 0.060		1.532 1.660 0.064		1.754 1.900 0.073		2.193 2.375 0.091		2.655 2.875 0.110		3.230 3.500 0.135		4.154 4.500 0.173		5.133 5.563 0.214		
Flow GPM	Velocity FPS	PSI LOSS	Velocity FPS	PSI LOSS	Velocity FPS	PSI LOSS	Velocity FPS	PSI LOSS	Velocity FPS	PSI LOSS	Velocity FPS	PSI LOSS	Velocity FPS	PSI LOSS	Velocity FPS	PSI LOSS	Flow GPM
1	0.29	0.02	0.17	0.01	0.13	0.00											1
2	0.57	0.06	0.35	0.02	0.27	0.01	0.17	0.00									2
3	0.86	0.14	0.52	0.04	0.40	0.02	0.25	0.01									3
4	1.14	0.23	0.70	0.07	0.53	0.04	0.34	0.01	0.23	0.00							4
5	1.43	0.35	0.87	0.11	0.66	0.05	0.42	0.02	0.29	0.01							5
6	1.71	0.49	1.04	0.15	0.80	0.08	0.51	0.03	0.35	0.01	0.23	0.00					6
7	2.00	0.66	1.22	0.20	0.93	0.10	0.59	0.03	0.41	0.01	0.27	0.01					7
8	2.29	0.84	1.39	0.25	1.06	0.13	0.68	0.04	0.46	0.02	0.31	0.01					8
9	2.57	1.05	1.56	0.31	1.19	0.16	0.76	0.05	0.52	0.02	0.35	0.01					9
10	2.86	1.27	1.74	0.38	1.33	0.20	0.85	0.07	0.58	0.03	0.39	0.01					10
11	3.14	1.52	1.91	0.45	1.46	0.23	0.93	0.08	0.64	0.03	0.43	0.01					11
12	3.43	1.78	2.09	0.53	1.59	0.28	1.02	0.09	0.69	0.04	0.47	0.01					12
13	3.71	2.07	2.26	0.62	1.72	0.32	1.10	0.11	0.75	0.04	0.51	0.02	0.31	0.00			13
14	4.00	2.37	2.43	0.71	1.86	0.37	1.19	0.12	0.81	0.05	0.55	0.02	0.33	0.01			14
15	4.29	2.70	2.61	0.80	1.99	0.42	1.27	0.14	0.87	0.06	0.59	0.02	0.35	0.01			15
16	4.57	3.04	2.78	0.91	2.12	0.47	1.36	0.16	0.93	0.06	0.63	0.02	0.38	0.01			16
17	4.86	3.40	2.96	1.01	2.25	0.53	1.44	0.18	0.98	0.07	0.66	0.03	0.40	0.01			17
18	5.14	3.78	3.13	1.13	2.39	0.58	1.53	0.20	1.04	0.08	0.70	0.03	0.43	0.01			18
19	5.43	4.18	3.30	1.25	2.52	0.65	1.61	0.22	1.10	0.09	0.74	0.03	0.45	0.01			19
20	5.71	4.59	3.48	1.37	2.65	0.71	1.70	0.24	1.16	0.09	0.78	0.04	0.47	0.01			20
22	6.29	5.48	3.82	1.64	2.92	0.85	1.87	0.29	1.27	0.11	0.86	0.04	0.52	0.01	0.34	0.00	22
24	6.86	6.44	4.17	1.92	3.18	0.99	2.04	0.34	1.39	0.13	0.94	0.05	0.57	0.01	0.37	0.01	24
25	7.14	6.94	4.35	2.07	3.32	1.07	2.12	0.36	1.45	0.14	0.98	0.05	0.59	0.02	0.39	0.01	25
26	7.43	7.47	4.52	2.23	3.45	1.15	2.21	0.39	1.50	0.15	1.02	0.06	0.61	0.02	0.40	0.01	26
28	8.00	8.56	4.87	2.56	3.71	1.32	2.38	0.45	1.62	0.18	1.09	0.07	0.66	0.02	0.43	0.01	28
30	8.57	9.73	5.22	2.91	3.98	1.50	2.55	0.51	1.74	0.20	1.17	0.08	0.71	0.02	0.46	0.01	30
32	9.14	10.97	5.56	3.27	4.24	1.69	2.71	0.57	1.85	0.23	1.25	0.09	0.76	0.03	0.50	0.01	32
34	9.71	12.27	5.91	3.66	4.51	1.90	2.88	0.64	1.97	0.25	1.33	0.10	0.80	0.03	0.53	0.01	34
35	10.00	12.95	6.08	3.87	4.64	2.00	2.97	0.67	2.03	0.27	1.37	0.10	0.83	0.03	0.54	0.01	35
36	10.29	13.64	6.26	4.07	4.77	2.11	3.05	0.71	2.08	0.28	1.41	0.11	0.85	0.03	0.56	0.01	36
38	10.86	15.08	6.61	4.50	5.04	2.33	3.22	0.79	2.20	0.31	1.49	0.12	0.90	0.04	0.59	0.01	38
40	11.43	16.58	6.95	4.95	5.30	2.56	3.39	0.86	2.32	0.34	1.56	0.13	0.95	0.04	0.62	0.01	40
42	12.00	18.15	7.30	5.42	5.57	2.80	3.56	0.95	2.43	0.37	1.64	0.14	0.99	0.04	0.65	0.02	42
44	12.57	19.78	7.65	5.91	5.84	3.06	3.73	1.03	2.55	0.41	1.72	0.16	1.04	0.05	0.68	0.02	44
45	12.86	20.62	7.82	6.16	5.97	3.19	3.82	1.07	2.60	0.42	1.76	0.16	1.06	0.05	0.70	0.02	45
46	13.14	21.48	8.00	6.41	6.10	3.32	3.90	1.12	2.66	0.44	1.80	0.17	1.09	0.05	0.71	0.02	46
48	13.71	23.24	8.34	6.94	6.37	3.59	4.07	1.21	2.78	0.48	1.88	0.18	1.13	0.05	0.74	0.02	48
50	14.29	25.07	8.69	7.48	6.63	3.87	4.24	1.31	2.89	0.52	1.96	0.20	1.18	0.06	0.77	0.02	50
55	15.71	29.90	9.56	8.93	7.29	4.62	4.67	1.56	3.18	0.61	2.15	0.24	1.30	0.07	0.85	0.02	55
60	17.14	35.13	10.43	10.49	7.96	5.43	5.09	1.83	3.47	0.72	2.35	0.28	1.42	0.08	0.93	0.03	60
65	18.57	40.75	11.30	12.16	8.62	6.30	5.51	2.12	3.76	0.84	2.54	0.32	1.54	0.09	1.01	0.03	65
70			12.17	13.95	9.28	7.22	5.94	2.44	4.05	0.96	2.74	0.37	1.66	0.11	1.08	0.04	70
75			13.04	15.86	9.95	8.21	6.36	2.77	4.34	1.09	2.93	0.42	1.77	0.12	1.16	0.04	75
80			13.91	17.87	10.61	9.25	6.79	3.12	4.63	1.23	3.13	0.47	1.89	0.14	1.24	0.05	80
85			14.78	19.99	11.27	10.35	7.21	3.49	4.92	1.38	3.32	0.53	2.01	0.16	1.32	0.06	85
90			15.65	22.23	11.94	11.50	7.64	3.88	5.21	1.53	3.52	0.59	2.13	0.17	1.39	0.06	90
95			16.51	24.57	12.60	12.72	8.06	4.29	5.50	1.69	3.72	0.65	2.25	0.19	1.47	0.07	95
100			17.38	27.01	13.26	13.98	8.48	4.72	5.79	1.86	3.91	0.72	2.36	0.21	1.55	0.08	100
110			19.12	32.23	14.59	16.68	9.33	5.63	6.37	2.22	4.30	0.85	2.60	0.25	1.70	0.09	110
120					15.91	19.60	10.18	6.61	6.95	2.61	4.69	1.00	2.84	0.30	1.86	0.11	120
130					17.24	22.73	11.03	7.67	7.52	3.02	5.08	1.16	3.07	0.34	2.01	0.12	130
140					18.57	26.08	11.88	8.79	8.10	3.47	5.47	1.34	3.31	0.39	2.17	0.14	140
150					19.89	29.63	12.73	9.99	8.68	3.94	5.87	1.52	3.55	0.45	2.32	0.16	150
160							13.57	11.26	9.28	4.44	6.26	1.71	3.78	0.50	2.48	0.18	160
170							14.42	12.60	9.84	4.97	6.65	1.91	4.02	0.56	2.63	0.20	170
180							15.27	14.01	10.42	5.52	7.04	2.13	4.26	0.63	2.79	0.22	180
190							16.12	15.48	11.00	6.11	7.43	2.35	4.49	0.69	2.94	0.25	190
200							16.97	17.02	11.58	6.72	7.82	2.59	4.73	0.76	3.10	0.27	200
225							19.09	21.17	13.02	8.35	8.80	3.22	5.32	0.95	3.48	0.34	225
250									14.47	10.15	9.78	3.91	5.91	1.15	3.87	0.41	250
275									15.92	12.11	10.75	4.67	6.50	1.37	4.26	0.49	275
300									17.36	14.23	11.73	5.48	7.09	1.61	4.65	0.58	300
325									18.81	16.50	12.71	6.36	7.68	1.87	5.03	0.67	325
350											13.69	7.29	8.28	2.14	5.42	0.77	350
375											14.67	8.29	8.87	2.44	5.81	0.87	375
400											15.64	9.34	9.46	2.75	6.19	0.98	400
425											16.62	10.45	10.05	3.07	6.58	1.10	425
450											17.60	11.62	10.64	3.41	6.97	1.22	450
475											18.58	12.84	11.23	3.77	7.36	1.35	475
500													11.82	4.15	7.74	1.48	500

Shaded area represents velocities over 5 FPS.
Use with caution where water hammer is a concern.

Friction Loss Characteristics Class 200 IPS PVC Plastic Pipe

(1120,1220) C=150 SDR 21
PSI Loss Per 100 Feet of Pipe Sizes 3/4" thru 4"

Nominal Size	3/4"		1"		1-1/4"		1-1/2"		2"		2-1/2"		3"		3-1/2"		4"		Nominal Size
	Pipe ID	Wall Thick	Velocity	PSI LOSS	Velocity	PSI LOSS	Velocity	PSI LOSS	Velocity	PSI LOSS	Velocity	PSI LOSS	Velocity	PSI LOSS	Velocity	PSI LOSS	Velocity	PSI LOSS	
1	0.47	0.06	0.29	0.02	0.18	0.01	0.14	0.00											1
2	0.94	0.22	0.58	0.07	0.36	0.02	0.28	0.01	0.18	0.00									2
3	1.42	0.46	0.87	0.14	0.54	0.04	0.41	0.02	0.27	0.01	0.18	0.00							3
4	1.89	0.79	1.15	0.24	0.72	0.08	0.55	0.04	0.35	0.01	0.24	0.01							4
5	2.36	1.19	1.44	0.36	0.90	0.12	0.69	0.06	0.44	0.02	0.30	0.01							5
6	2.83	1.67	1.73	0.51	1.09	0.16	0.83	0.08	0.53	0.03	0.36	0.01	0.24	0.00					6
7	3.30	2.23	2.02	0.67	1.27	0.22	0.97	0.11	0.62	0.04	0.42	0.01	0.28	0.01					7
8	3.77	2.85	2.31	0.86	1.45	0.28	1.10	0.14	0.71	0.05	0.48	0.02	0.33	0.01					8
9	4.25	3.55	2.60	1.07	1.63	0.34	1.24	0.18	0.80	0.06	0.54	0.02	0.37	0.01	0.28	0.00			9
10	4.72	4.31	2.89	1.30	1.81	0.42	1.38	0.22	0.88	0.07	0.60	0.03	0.41	0.01	0.31	0.01			10
12	5.66	6.04	3.46	1.83	2.17	0.59	1.65	0.30	1.06	0.10	0.72	0.04	0.49	0.02	0.37	0.01	0.30	0.00	12
14	6.80	8.04	4.04	2.43	2.53	0.78	1.93	0.40	1.24	0.14	0.84	0.05	0.57	0.02	0.44	0.01	0.34	0.01	14
15	7.08	9.13	4.33	2.76	2.71	0.89	2.07	0.46	1.33	0.16	0.90	0.06	0.61	0.02	0.47	0.01	0.37	0.01	15
16	7.55	10.29	4.62	3.11	2.89	1.00	2.21	0.52	1.41	0.17	0.96	0.07	0.65	0.03	0.50	0.01	0.39	0.01	16
18	8.49	12.80	5.19	3.87	3.26	1.24	2.48	0.64	1.59	0.22	1.09	0.09	0.73	0.03	0.56	0.02	0.44	0.01	18
20	9.43	15.56	5.77	4.71	3.62	1.51	2.76	0.78	1.77	0.26	1.21	0.10	0.81	0.04	0.62	0.02	0.49	0.01	20
22	10.38	18.56	6.35	5.62	3.98	1.80	3.03	0.93	1.94	0.32	1.33	0.12	0.90	0.05	0.68	0.02	0.54	0.01	22
24	11.32	21.81	6.93	6.60	4.34	2.12	3.31	1.09	2.12	0.37	1.45	0.15	0.98	0.06	0.75	0.03	0.59	0.02	24
25	11.79	23.52	7.22	7.12	4.52	2.28	3.45	1.18	2.21	0.40	1.51	0.16	1.02	0.06	0.78	0.03	0.62	0.02	25
26	12.27	25.29	7.50	7.65	4.70	2.45	3.59	1.27	2.30	0.43	1.57	0.17	1.06	0.07	0.81	0.03	0.64	0.02	26
28	13.21	29.01	8.08	8.78	5.06	2.82	3.86	1.46	2.47	0.49	1.69	0.19	1.14	0.07	0.87	0.04	0.69	0.02	28
30	14.15	32.96	8.66	9.97	5.43	3.20	4.14	1.65	2.65	0.56	1.81	0.22	1.22	0.08	0.93	0.04	0.74	0.02	30
32	15.10	37.15	9.24	11.24	5.79	3.61	4.41	1.86	2.83	0.63	1.93	0.25	1.30	0.10	1.00	0.05	0.79	0.03	32
34	16.04	41.56	9.81	12.58	6.15	4.03	4.69	2.09	3.00	0.71	2.05	0.28	1.38	0.11	1.06	0.06	0.84	0.03	34
35	16.51	43.86	10.10	13.27	6.33	4.26	4.83	2.20	3.09	0.74	2.11	0.29	1.42	0.11	1.09	0.06	0.86	0.03	35
36	16.98	46.21	10.39	13.98	6.51	4.48	4.96	2.32	3.18	0.78	2.17	0.31	1.47	0.12	1.12	0.06	0.89	0.03	36
38	17.93	51.07	10.97	15.45	6.87	4.96	5.24	2.56	3.36	0.87	2.29	0.34	1.55	0.13	1.18	0.07	0.94	0.04	38
40	18.87	56.16	11.54	16.99	7.23	5.45	5.52	2.82	3.53	0.95	2.41	0.38	1.63	0.14	1.25	0.08	0.98	0.04	40
42	19.81	61.47	12.12	18.60	7.60	5.97	5.79	3.08	3.71	1.04	2.53	0.41	1.71	0.16	1.31	0.08	1.03	0.05	42
44	20.76	67.00	12.70	20.27	7.96	6.50	6.07	3.36	3.89	1.14	2.65	0.45	1.79	0.17	1.37	0.09	1.08	0.05	44
45			12.99	21.13	8.14	6.78	6.21	3.51	3.98	1.19	2.71	0.47	1.83	0.18	1.40	0.09	1.11	0.05	45
46			13.28	22.01	8.32	7.06	6.34	3.65	4.06	1.24	2.77	0.49	1.87	0.19	1.43	0.10	1.13	0.06	46
48			13.85	23.82	8.68	7.64	6.62	3.95	4.24	1.34	2.89	0.53	1.95	0.20	1.49	0.11	1.18	0.06	48
50			14.43	25.69	9.04	8.24	6.90	4.26	4.42	1.44	3.02	0.57	2.04	0.22	1.56	0.11	1.23	0.06	50
55			15.87	30.65	9.95	9.83	7.59	5.08	4.86	1.72	3.32	0.68	2.24	0.26	1.71	0.14	1.35	0.08	55
60			17.32	36.00	10.85	11.55	8.27	5.97	5.30	2.02	3.62	0.80	2.44	0.31	1.87	0.16	1.48	0.09	60
65			18.76	41.76	11.76	13.39	8.96	6.93	5.74	2.34	3.92	0.93	2.65	0.36	2.02	0.19	1.60	0.10	65
70					12.66	15.36	9.65	7.95	6.18	2.69	4.22	1.06	2.85	0.41	2.18	0.21	1.72	0.12	70
75					13.56	17.46	10.34	9.03	6.63	3.05	4.52	1.21	3.05	0.46	2.34	0.24	1.85	0.14	75
80					14.47	19.67	11.03	10.17	7.07	3.44	4.82	1.36	3.26	0.52	2.49	0.27	1.97	0.15	80
85					15.37	22.01	11.72	11.38	7.51	3.85	5.13	1.52	3.46	0.58	2.65	0.30	2.09	0.17	85
90					16.28	24.47	12.41	12.65	7.95	4.28	5.43	1.69	3.66	0.65	2.80	0.34	2.21	0.19	90
95					17.18	27.05	13.10	13.99	8.39	4.73	5.73	1.87	3.87	0.72	2.96	0.37	2.34	0.21	95
100					18.09	29.74	13.79	15.38	8.83	5.20	6.03	2.06	4.07	0.79	3.11	0.41	2.46	0.23	100
110					19.89	35.48	15.17	18.35	9.72	6.21	6.63	2.45	4.48	0.94	3.42	0.49	2.71	0.28	110
120							16.55	21.56	10.60	7.30	7.24	2.88	4.88	1.11	3.74	0.58	2.95	0.33	120
130							17.93	25.00	11.48	8.46	7.84	3.34	5.29	1.28	4.05	0.67	3.20	0.38	130
140							19.31	28.68	12.37	9.71	8.44	3.83	5.70	1.47	4.36	0.77	3.44	0.43	140
150									13.25	11.03	9.05	4.36	6.11	1.67	4.67	0.87	3.69	0.49	150
175									15.46	14.67	10.55	5.80	7.12	2.29	5.45	1.16	4.31	0.65	175
200									17.67	18.79	12.06	7.42	8.14	2.85	6.23	1.49	4.92	0.84	200
225									19.88	23.37	13.57	9.23	9.16	3.55	7.01	1.85	5.54	1.04	225
250											15.08	11.22	10.18	4.31	7.78	2.25	6.15	1.27	250
275											16.58	13.39	11.19	5.14	8.56	2.68	6.77	1.51	275
300											18.09	15.73	12.21	6.04	9.34	3.15	7.38	1.78	300
350													14.25	8.04	10.90	4.19	8.61	2.36	350
400													16.28	10.29	12.45	5.36	9.84	3.03	400
450													18.92	12.80	14.01	6.67	11.07	3.76	450
500															15.57	8.11	12.30	4.57	500
550															17.12	9.67	13.53	5.46	550
600															18.68	11.36	14.76	6.41	600
700																	17.22	8.53	700
800																	19.68	10.92	800

Shaded area represents velocities over 5 FPS.
Use with caution where water hammer is a concern.

Friction Loss Characteristics Class 315 IPS PVC Plastic Pipe

(1120,1220) C=150 SDR 13.5
PSI Loss Per 100 Feet of Pipe Sizes 1/2" thru 3"

Nominal Size	1/2"		3/4"		1"		1 1/4"		1 1/2"		2"		2 1/2"		3"		Nominal Size
Pipe ID	0.716		0.894		1.121		1.414		1.618		2.023		2.449		2.982		Pipe ID
Pipe OD	0.840		1.050		1.315		1.660		1.900		2.375		2.875		3.500		Pipe OD
Wall Thick	0.062		0.078		0.097		0.123		0.141		0.176		0.213		0.259		Wall Thick
Flow GPM	Velocity FPS	PSI LOSS	Velocity FPS	PSI LOSS	Velocity FPS	PSI LOSS	Velocity FPS	PSI LOSS	Velocity FPS	PSI LOSS	Velocity FPS	PSI LOSS	Velocity FPS	PSI LOSS	Velocity FPS	PSI LOSS	Flow GPM
1	0.80	0.22	0.51	0.07	0.32	0.02	0.20	0.01	0.16	0.00							1
2	1.59	0.78	1.02	0.27	0.65	0.09	0.41	0.03	0.31	0.01	0.20	0.00					2
3	2.39	1.65	1.53	0.56	0.97	0.19	0.61	0.06	0.47	0.03	0.30	0.01	0.20	0.00			3
4	3.18	2.82	2.04	0.96	1.30	0.32	0.82	0.10	0.62	0.05	0.40	0.02	0.27	0.01			4
5	3.98	4.26	2.55	1.45	1.62	0.48	1.02	0.16	0.78	0.08	0.50	0.03	0.34	0.01	0.23	0.00	5
6	4.78	5.97	3.06	2.03	1.95	0.67	1.22	0.22	0.94	0.11	0.60	0.04	0.41	0.02	0.28	0.01	6
7	5.57	7.95	3.57	2.70	2.27	0.90	1.43	0.29	1.09	0.15	0.70	0.05	0.48	0.02	0.32	0.01	7
8	6.37	10.18	4.08	3.45	2.60	1.15	1.63	0.37	1.25	0.19	0.80	0.06	0.54	0.03	0.37	0.01	8
9	7.16	12.66	4.59	4.30	2.92	1.43	1.84	0.46	1.40	0.24	0.90	0.08	0.61	0.03	0.41	0.01	9
10	7.96	15.38	5.10	5.22	3.25	1.74	2.04	0.56	1.56	0.29	1.00	0.10	0.68	0.04	0.46	0.01	10
11	8.75	18.35	5.62	6.23	3.57	2.07	2.24	0.67	1.71	0.35	1.10	0.12	0.75	0.05	0.50	0.02	11
12	9.55	21.56	6.13	7.32	3.90	2.43	2.45	0.79	1.87	0.41	1.20	0.14	0.82	0.05	0.55	0.02	12
13	10.35	25.01	6.64	8.49	4.22	2.82	2.65	0.91	2.03	0.47	1.30	0.16	0.88	0.06	0.60	0.02	13
14	11.14	28.69	7.15	9.74	4.55	3.24	2.86	1.05	2.18	0.54	1.40	0.18	0.95	0.07	0.64	0.03	14
15	11.94	32.60	7.66	11.07	4.87	3.68	3.06	1.19	2.34	0.62	1.50	0.21	1.02	0.08	0.69	0.03	15
16	12.73	36.73	8.17	12.47	5.19	4.15	3.26	1.34	2.49	0.70	1.60	0.23	1.09	0.09	0.73	0.04	16
17	13.53	41.10	8.68	13.95	5.52	4.64	3.47	1.50	2.65	0.78	1.69	0.26	1.16	0.10	0.78	0.04	17
18	14.33	45.69	9.19	15.51	5.84	5.16	3.67	1.67	2.81	0.86	1.79	0.29	1.22	0.12	0.83	0.04	18
19	15.12	50.50	9.70	17.14	6.17	5.70	3.88	1.84	2.96	0.96	1.89	0.32	1.29	0.13	0.87	0.05	19
20	15.92	55.53	10.21	18.85	6.49	6.27	4.08	2.03	3.12	1.05	1.99	0.35	1.36	0.14	0.92	0.05	20
22	17.51	66.25	11.23	22.49	7.14	7.48	4.49	2.42	3.43	1.25	2.19	0.42	1.50	0.17	1.01	0.06	22
24	19.10	77.84	12.25	26.42	7.79	8.79	4.90	2.84	3.74	1.47	2.39	0.50	1.63	0.20	1.10	0.08	24
25			12.76	28.50	8.12	9.48	5.10	3.06	3.90	1.59	2.49	0.54	1.70	0.21	1.15	0.08	25
26			13.27	30.65	8.44	10.19	5.31	3.29	4.05	1.71	2.59	0.58	1.77	0.23	1.19	0.09	26
28			14.29	35.15	9.09	11.69	5.71	3.78	4.36	1.96	2.79	0.66	1.90	0.26	1.28	0.10	28
30			15.31	39.95	9.74	13.28	6.12	4.29	4.68	2.23	2.99	0.75	2.04	0.30	1.38	0.11	30
32			16.34	45.02	10.39	14.97	6.53	4.84	4.99	2.51	3.19	0.85	2.18	0.33	1.47	0.13	32
34			17.36	50.37	11.04	16.75	6.94	5.41	5.30	2.81	3.39	0.95	2.31	0.37	1.56	0.14	34
35			17.87	53.14	11.36	17.67	7.14	5.71	5.45	2.96	3.49	1.00	2.38	0.39	1.61	0.15	35
36			18.38	55.99	11.69	18.62	7.35	6.02	5.61	3.12	3.59	1.05	2.45	0.42	1.65	0.16	36
38			19.40	61.89	12.34	20.58	7.75	6.65	5.92	3.45	3.79	1.16	2.59	0.46	1.74	0.18	38
40					12.99	22.63	8.16	7.31	6.23	3.79	3.99	1.28	2.72	0.50	1.84	0.19	40
42					13.64	24.77	8.57	8.00	6.55	4.15	4.19	1.40	2.86	0.55	1.93	0.21	42
44					14.29	27.00	8.98	8.72	6.86	4.53	4.39	1.53	2.99	0.60	2.02	0.23	44
45					14.61	28.15	9.18	9.09	7.01	4.72	4.49	1.59	3.06	0.63	2.06	0.24	45
46					14.94	29.32	9.39	9.47	7.17	4.92	4.59	1.66	3.13	0.65	2.11	0.25	46
48					15.58	31.72	9.79	10.25	7.48	5.32	4.79	1.79	3.27	0.71	2.20	0.27	48
50					16.23	34.21	10.20	11.05	7.79	5.74	4.98	1.93	3.40	0.76	2.29	0.29	50
55					17.86	40.82	11.22	13.19	8.57	6.84	5.48	2.31	3.74	0.91	2.52	0.35	55
60					19.48	47.95	12.24	15.49	9.35	8.04	5.98	2.71	4.08	1.07	2.75	0.41	60
65							13.26	17.97	10.13	9.33	6.48	3.14	4.42	1.24	2.98	0.48	65
70							14.28	20.61	10.91	10.70	6.98	3.61	4.76	1.42	3.21	0.55	70
75							15.30	23.42	11.69	12.16	7.48	4.10	5.10	1.62	3.44	0.62	75
80							16.32	26.39	12.47	13.70	7.98	4.62	5.44	1.82	3.67	0.70	80
85							17.35	29.53	13.25	15.33	8.47	5.17	5.78	2.04	3.90	0.78	85
90							18.37	32.83	14.03	17.04	8.97	5.75	6.12	2.27	4.13	0.87	90
95							19.39	36.28	14.81	18.83	9.47	6.35	6.46	2.51	4.36	0.96	95
100									15.58	20.71	9.97	6.98	6.80	2.76	4.59	1.06	100
110									17.14	24.71	10.97	8.33	7.48	3.29	5.05	1.26	110
120									18.70	29.03	11.96	9.79	8.16	3.86	5.51	1.48	120
130									12.96	11.35	8.84	4.48	9.56	1.72	130		
140									13.96	13.02	9.52	5.14	6.42	1.97	140		
150									14.95	14.80	10.20	5.84	6.88	2.24	150		
175									17.45	19.69	11.90	7.77	8.03	2.98	175		
200									19.94	25.21	13.61	9.95	9.18	3.82	200		
225											15.31	12.37	10.32	4.75	225		
250											17.01	15.04	11.47	5.77	250		
275											18.71	17.94	12.62	6.88	275		
300													13.76	8.09	300		
325													14.91	9.38	325		
350													16.06	10.76	350		
400													18.35	13.78	400		

Shaded area represents velocities over 5 FPS.
Use with caution where water hammer is a concern.

Friction Loss Characteristics Schedule 40 IPS PVC Plastic Pipe

(1120,1220) C=150 PSI Loss Per 100 Feet of Pipe
Sizes 1/2" thru 3"

Nominal Size Pipe ID Pipe OD Wall Thick	1/2"		3/4"		1"		1 1/4"		1 1/2"		2"		2 1/2"		3"		Nominal Size Pipe ID Pipe OD Wall Thick
	Velocity FPS	PSI LOSS	Velocity FPS	PSI LOSS	Velocity FPS	PSI LOSS	Velocity FPS	PSI LOSS	Velocity FPS	PSI LOSS	Velocity FPS	PSI LOSS	Velocity FPS	PSI LOSS	Velocity FPS	PSI LOSS	
1	1.05	0.43	0.60	0.11	0.37	0.03	0.21	0.01	0.16	0.00							1
2	2.11	1.55	1.20	0.39	0.74	0.12	0.43	0.03	0.31	0.02	0.19	0.00					2
3	3.16	3.28	1.80	0.84	1.11	0.26	0.64	0.07	0.47	0.03	0.29	0.01	0.20	0.00			3
4	4.22	5.59	2.40	1.42	1.48	0.44	0.86	0.12	0.63	0.05	0.38	0.02	0.27	0.01			4
5	5.27	8.45	3.00	2.15	1.85	0.66	1.07	0.17	0.79	0.08	0.48	0.02	0.33	0.01	0.22	0.00	5
6	6.33	11.85	3.61	3.02	2.22	0.93	1.29	0.25	0.94	0.12	0.57	0.03	0.40	0.01	0.26	0.01	6
7	7.38	15.76	4.21	4.01	2.60	1.24	1.50	0.33	1.10	0.15	0.67	0.05	0.47	0.02	0.30	0.01	7
8	8.44	20.18	4.81	5.14	2.97	1.59	1.71	0.42	1.26	0.20	0.76	0.06	0.54	0.02	0.35	0.01	8
9	9.49	25.10	5.41	6.39	3.34	1.97	1.93	0.52	1.42	0.25	0.86	0.07	0.60	0.03	0.39	0.01	9
10	10.55	30.51	6.01	7.77	3.71	2.40	2.14	0.63	1.57	0.30	0.95	0.09	0.67	0.04	0.43	0.01	10
11	11.60	36.40	6.61	9.26	4.08	2.86	2.36	0.75	1.73	0.36	1.05	0.11	0.74	0.04	0.48	0.02	11
12	12.65	42.77	7.21	10.88	4.45	3.36	2.57	0.89	1.89	0.42	1.15	0.12	0.80	0.05	0.52	0.02	12
13	13.71	49.60	7.81	12.62	4.82	3.90	2.79	1.03	2.05	0.48	1.24	0.14	0.87	0.06	0.56	0.02	13
14	14.76	56.90	8.41	14.48	5.19	4.47	3.00	1.18	2.20	0.56	1.34	0.16	0.94	0.07	0.61	0.02	14
15	15.82	64.65	9.01	16.45	5.56	5.08	3.21	1.34	2.36	0.63	1.43	0.19	1.00	0.08	0.65	0.03	15
16	16.87	72.86	9.61	18.54	5.93	5.73	3.43	1.51	2.52	0.71	1.53	0.21	1.07	0.09	0.69	0.03	16
17	17.93	81.52	10.22	20.75	6.30	6.41	3.64	1.69	2.68	0.80	1.62	0.24	1.14	0.10	0.74	0.03	17
18	18.98	90.62	10.82	23.06	6.67	7.12	3.86	1.88	2.83	0.89	1.72	0.26	1.20	0.11	0.78	0.04	18
19			11.42	25.49	7.04	7.87	4.07	2.07	2.99	0.98	1.81	0.29	1.27	0.12	0.82	0.04	19
20			12.02	28.03	7.42	8.66	4.28	2.28	3.15	1.08	1.91	0.32	1.34	0.13	0.87	0.05	20
22			13.22	33.44	8.16	10.33	4.71	2.72	3.46	1.28	2.10	0.38	1.47	0.16	0.95	0.06	22
24			14.42	39.29	8.90	12.14	5.14	3.20	3.78	1.51	2.29	0.45	1.61	0.19	1.04	0.07	24
25			15.02	42.38	9.27	13.09	5.36	3.45	3.94	1.63	2.39	0.48	1.67	0.20	1.08	0.07	25
26			15.62	45.57	9.64	14.08	5.57	3.71	4.09	1.75	2.48	0.52	1.74	0.22	1.13	0.08	26
28			16.83	52.27	10.38	16.15	6.00	4.25	4.41	2.01	2.67	0.60	1.87	0.25	1.21	0.09	28
30			18.03	59.40	11.12	18.35	6.43	4.83	4.72	2.28	2.86	0.68	2.01	0.28	1.30	0.10	30
32			19.23	66.94	11.86	20.68	6.86	5.44	5.04	2.57	3.06	0.76	2.14	0.32	1.39	0.11	32
34					12.61	23.13	7.28	6.09	5.35	2.88	3.25	0.85	2.28	0.36	1.47	0.12	34
35					12.98	24.41	7.50	6.43	5.51	3.04	3.34	0.90	2.34	0.38	1.52	0.13	35
36					13.35	25.72	7.71	6.77	5.67	3.20	3.44	0.95	2.41	0.40	1.56	0.14	36
38					14.09	28.43	8.14	7.48	5.98	3.54	3.63	1.05	2.54	0.44	1.65	0.15	38
40					14.83	31.26	8.57	8.23	6.30	3.89	3.82	1.15	2.68	0.49	1.73	0.17	40
42					15.57	34.22	9.00	9.01	6.61	4.25	4.01	1.26	2.81	0.53	1.82	0.18	42
44					16.31	37.29	9.43	9.82	6.93	4.64	4.20	1.37	2.94	0.58	1.91	0.20	44
45					16.68	38.88	9.64	10.24	7.08	4.83	4.30	1.43	3.01	0.60	1.95	0.21	45
46					17.06	40.49	9.86	10.66	7.24	5.04	4.39	1.49	3.08	0.63	1.99	0.22	46
48					17.80	43.81	10.28	11.54	7.56	5.45	4.58	1.62	3.21	0.68	2.08	0.24	48
50					18.54	47.26	10.71	12.44	7.87	5.88	4.77	1.74	3.35	0.73	2.17	0.25	50
55					11.78	14.84	8.66	7.01	8.66	7.01	5.25	2.08	3.68	0.88	2.38	0.30	55
60					12.85	17.44	9.44	8.24	9.44	8.24	5.73	2.44	4.02	1.03	2.60	0.36	60
65					13.93	20.23	10.23	9.55	10.23	9.55	6.21	2.83	4.35	1.19	2.82	0.41	65
70					15.00	23.20	11.02	10.96	11.02	10.96	6.68	3.25	4.69	1.37	3.03	0.48	70
75					16.07	26.36	11.81	12.45	11.81	12.45	7.16	3.69	5.02	1.55	3.25	0.54	75
80					17.14	29.71	12.59	14.03	12.59	14.03	7.64	4.16	5.35	1.75	3.47	0.61	80
85					18.21	33.24	13.38	15.70	13.38	15.70	8.12	4.65	5.69	1.96	3.68	0.68	85
90					19.28	36.95	14.17	17.45	14.17	17.45	8.59	5.17	6.02	2.18	3.90	0.76	90
95							14.95	19.29	14.95	19.29	9.07	5.72	6.36	2.41	4.12	0.84	95
100							15.74	21.21	15.74	21.21	9.55	6.29	6.69	2.65	4.33	0.92	100
110							17.31	25.31	17.31	25.31	10.50	7.50	7.36	3.16	4.77	1.10	110
120							18.89	29.74	18.89	29.74	11.46	8.82	8.03	3.71	5.20	1.29	120
130											12.41	10.22	8.70	4.31	5.63	1.50	130
140											13.37	11.73	9.37	4.94	6.07	1.72	140
150											14.32	13.33	10.04	5.61	6.50	1.95	150
160											15.28	15.02	10.71	6.33	6.94	2.20	160
170											16.23	16.80	11.38	7.08	7.37	2.46	170
180											17.19	18.68	12.05	7.87	7.80	2.73	180
190											18.14	20.65	12.72	8.70	8.24	3.02	190
200											19.10	22.70	13.39	9.56	8.67	3.32	200
225													15.06	11.89	9.75	4.13	225
250													16.73	14.46	10.84	5.02	250
275													18.41	17.25	11.92	5.99	275
300															13.00	7.04	300
325															14.09	8.17	325
350															15.17	9.37	350
375															16.25	10.64	375
400															17.34	12.00	400

Shaded area represents velocities over 5 FPS.
Use with caution where water hammer is a concern.

Friction Loss Characteristics Schedule 40 Standard Steel Pipe

C=100 Sizes 1/2" thru 3"
PSI Loss Per 100 Feet of Pipe

Nominal Size Pipe ID Pipe OD Wall Thick	1/2"		3/4"		1"		1 1/4"		1 1/2"		2"		2 1/2"		3"		Nominal Size Pipe ID Pipe OD Wall Thick
	Flow GPM	Velocity FPS	PSI LOSS	Velocity FPS	PSI LOSS	Velocity FPS	PSI LOSS	Velocity FPS	PSI LOSS	Velocity FPS	PSI LOSS	Velocity FPS	PSI LOSS	Velocity FPS	PSI LOSS	Velocity FPS	
1	1.05	0.91	0.60	0.23	0.37	0.07	0.21	0.02	0.16	0.01	0.10	0.00	0.13	0.00	0.13	0.00	1
2	2.11	3.28	1.20	0.84	0.74	0.26	0.43	0.07	0.31	0.03	0.19	0.01	0.27	0.01	0.27	0.01	2
3	3.16	6.95	1.80	1.77	1.11	0.55	0.64	0.14	0.47	0.07	0.29	0.02	0.40	0.02	0.40	0.02	3
4	4.22	11.85	2.40	3.02	1.48	0.93	0.86	0.25	0.63	0.12	0.38	0.03	0.54	0.03	0.54	0.03	4
5	5.27	17.91	3.00	4.56	1.85	1.41	1.07	0.37	0.79	0.18	0.48	0.05	0.73	0.05	0.73	0.05	5
6	6.33	25.10	3.61	6.39	2.22	1.97	1.29	0.52	0.94	0.25	0.57	0.07	0.90	0.07	0.90	0.07	6
7	7.38	33.40	4.21	8.50	2.60	2.63	1.50	0.69	1.10	0.33	0.67	0.10	1.17	0.10	1.17	0.10	7
8	8.44	42.77	4.81	10.88	2.97	3.36	1.71	0.89	1.26	0.42	0.76	0.12	1.44	0.12	1.44	0.12	8
9	9.49	53.19	5.41	13.54	3.34	4.18	1.93	1.10	1.42	0.52	0.86	0.15	1.72	0.15	1.72	0.15	9
10	10.55	64.65	6.01	16.45	3.71	5.08	2.14	1.34	1.57	0.63	0.95	0.19	2.00	0.19	2.00	0.19	10
11	11.60	77.14	6.61	19.63	4.08	6.06	2.36	1.60	1.73	0.75	1.05	0.22	2.28	0.22	2.28	0.22	11
12	12.65	90.62	7.21	23.06	4.45	7.12	2.57	1.88	1.89	0.89	1.15	0.26	2.56	0.26	2.56	0.26	12
13	13.71	105.1	7.81	26.75	4.82	8.26	2.79	2.18	2.05	1.03	1.24	0.30	2.84	0.30	2.84	0.30	13
14	14.76	120.6	8.41	30.68	5.19	9.48	3.00	2.50	2.20	1.18	1.34	0.35	3.12	0.35	3.12	0.35	14
15	15.82	137.0	9.01	34.87	5.56	10.77	3.21	2.84	2.36	1.34	1.43	0.40	3.40	0.40	3.40	0.40	15
16	16.87	154.4	9.61	39.29	5.93	12.14	3.43	3.20	2.52	1.51	1.53	0.45	3.68	0.45	3.68	0.45	16
17	17.93	172.7	10.22	43.96	6.30	13.58	3.64	3.58	2.68	1.69	1.62	0.50	3.96	0.50	3.96	0.50	17
18	18.98	192.0	10.82	48.87	6.67	15.10	3.86	3.97	2.83	1.88	1.72	0.56	4.24	0.56	4.24	0.56	18
19			11.42	54.02	7.04	16.69	4.07	4.39	2.99	2.07	1.81	0.62	4.52	0.62	4.52	0.62	19
20			12.02	59.40	7.42	18.35	4.28	4.83	3.15	2.28	1.91	0.68	4.80	0.68	4.80	0.68	20
22			13.22	70.87	8.16	21.89	4.71	5.76	3.46	2.72	2.10	0.81	5.36	0.81	5.36	0.81	22
24			14.42	83.26	8.90	25.72	5.14	6.77	3.78	3.20	2.29	0.95	6.00	0.95	6.00	0.95	24
25			15.02	89.80	9.27	27.74	5.36	7.30	3.94	3.45	2.39	1.02	6.32	1.02	6.32	1.02	25
26			15.62	96.56	9.64	29.83	5.57	7.85	4.09	3.71	2.48	1.10	6.64	1.10	6.64	1.10	26
28			16.83	110.8	10.38	34.22	6.00	9.01	4.41	4.25	2.67	1.26	7.32	1.26	7.32	1.26	28
30			18.03	125.9	11.12	38.88	6.43	10.24	4.72	4.83	2.86	1.43	8.04	1.43	8.04	1.43	30
32					11.86	43.81	6.86	11.54	5.04	5.45	3.06	1.62	8.76	1.62	8.76	1.62	32
34					12.61	49.02	7.28	12.91	5.35	6.10	3.25	1.81	9.48	1.81	9.48	1.81	34
35					12.98	51.72	7.50	13.62	5.51	6.43	3.34	1.91	9.80	1.91	9.80	1.91	35
36					13.35	54.49	7.71	14.35	5.67	6.78	3.44	2.01	10.12	2.01	10.12	2.01	36
38					14.09	60.23	8.14	15.86	5.98	7.49	3.63	2.22	10.84	2.22	10.84	2.22	38
40					14.83	66.24	8.57	17.44	6.30	8.24	3.82	2.44	11.56	2.44	11.56	2.44	40
42					15.57	72.50	9.00	19.09	6.61	9.02	4.01	2.67	12.28	2.67	12.28	2.67	42
44					16.31	79.02	9.43	20.81	6.93	9.83	4.20	2.91	13.00	2.91	13.00	2.91	44
45					16.68	82.38	9.64	21.69	7.08	10.25	4.30	3.04	13.32	3.04	13.32	3.04	45
46					17.06	85.80	9.86	22.59	7.24	10.67	4.39	3.16	13.64	3.16	13.64	3.16	46
48					17.80	92.84	10.28	24.44	7.56	11.55	4.58	3.42	14.36	3.42	14.36	3.42	48
50					18.54	100.1	10.71	26.36	7.87	12.45	4.77	3.69	15.08	3.69	15.08	3.69	50
55							11.78	31.45	8.66	14.86	5.25	4.40	16.50	4.40	16.50	4.40	55
60							12.85	36.95	9.44	17.45	5.73	5.17	18.00	5.17	18.00	5.17	60
65							13.93	42.86	10.23	20.24	6.21	6.00	19.50	6.00	19.50	6.00	65
70							15.00	49.16	11.02	23.22	6.68	6.88	21.00	6.88	21.00	6.88	70
75							16.07	55.86	11.81	26.39	7.16	7.82	22.50	7.82	22.50	7.82	75
80							17.14	62.96	12.59	29.74	7.64	8.82	24.00	8.82	24.00	8.82	80
85							18.21	70.44	13.38	33.27	8.12	9.86	25.50	9.86	25.50	9.86	85
90									14.17	36.98	8.59	10.96	27.00	10.96	27.00	10.96	90
95									14.95	40.88	9.07	12.12	28.50	12.12	28.50	12.12	95
100									15.74	44.95	9.55	13.33	30.00	13.33	30.00	13.33	100
110									17.31	53.63	10.50	15.90	33.00	15.90	33.00	15.90	110
120									18.89	63.01	11.46	18.68	36.00	18.68	36.00	18.68	120
130											12.41	21.66	39.00	21.66	39.00	21.66	130
140											13.37	24.85	42.00	24.85	42.00	24.85	140
150											14.32	28.24	45.00	28.24	45.00	28.24	150
160											15.28	31.82	48.00	31.82	48.00	31.82	160
170											16.23	35.61	51.00	35.61	51.00	35.61	170
180											17.19	39.58	54.00	39.58	54.00	39.58	180
190											18.14	43.75	57.00	43.75	57.00	43.75	190
200													13.39	20.26	8.67	7.04	200
225													15.06	25.20	9.75	8.76	225
250													16.73	30.63	10.84	10.64	250
275													18.41	36.54	11.92	12.70	275
300															13.00	14.92	300
325															14.09	17.30	325
350															15.17	19.85	350
375															16.25	22.56	375
400															17.34	25.42	400

Shaded area represents velocities over 5 FPS.
Use with caution where water hammer is a concern.

Friction Loss Characteristics Polyethylene (PE) Pipe - SDR Pressure Rated Tube

C=140 SDR 7, 9, 11.5, 15 Sizes 1/2" thru 2"
PSI Loss Per 100 Feet of Pipe

Nominal Size Pipe ID	1/2" 0.622		3/4" 0.824		1" 1.049		1-1/4" 1.380		1-1/2" 1.610		2" 2.067		Nominal Size Pipe ID
Flow GPM	Velocity FPS	PSI LOSS	Velocity FPS	PSI LOSS	Velocity FPS	PSI LOSS	Velocity FPS	PSI LOSS	Velocity FPS	PSI LOSS	Velocity FPS	PSI LOSS	Flow GPM
1	1.05	0.49	0.60	0.12	0.37	0.04	0.21	0.01	0.16	0.00	0.10	0.00	1
2	2.11	1.76	1.20	0.45	0.74	0.14	0.43	0.04	0.31	0.02	0.19	0.01	2
3	3.16	3.73	1.80	0.95	1.11	0.29	0.64	0.08	0.47	0.04	0.29	0.01	3
4	4.22	6.35	2.40	1.62	1.48	0.50	0.86	0.13	0.63	0.06	0.38	0.02	4
5	5.27	9.60	3.00	2.44	1.85	0.76	1.07	0.20	0.79	0.09	0.48	0.03	5
6	6.33	13.46	3.61	3.43	2.22	1.06	1.29	0.28	0.94	0.13	0.57	0.04	6
7	7.38	17.91	4.21	4.56	2.60	1.41	1.50	0.37	1.10	0.18	0.67	0.05	7
8	8.44	22.93	4.81	5.84	2.97	1.80	1.71	0.47	1.26	0.22	0.76	0.07	8
9	9.49	28.52	5.41	7.26	3.34	2.24	1.93	0.59	1.42	0.28	0.86	0.08	9
10	10.55	34.67	6.01	8.82	3.71	2.73	2.14	0.72	1.57	0.34	0.95	0.10	10
11	11.60	41.36	6.61	10.53	4.08	3.25	2.36	0.86	1.73	0.40	1.05	0.12	11
12	12.65	48.60	7.21	12.37	4.45	3.82	2.57	1.01	1.89	0.48	1.15	0.14	12
13	13.71	56.36	7.81	14.34	4.82	4.43	2.79	1.17	2.05	0.55	1.24	0.16	13
14	14.76	64.65	8.41	16.45	5.19	5.08	3.00	1.34	2.20	0.63	1.34	0.19	14
15	15.82	73.47	9.01	18.70	5.56	5.78	3.21	1.52	2.36	0.72	1.43	0.21	15
16	16.87	82.79	9.61	21.07	5.93	6.51	3.43	1.71	2.52	0.81	1.53	0.24	16
17	17.93	92.63	10.22	23.57	6.30	7.28	3.64	1.92	2.68	0.91	1.62	0.27	17
18	18.98	103.0	10.82	26.21	6.67	8.10	3.86	2.13	2.83	1.01	1.72	0.30	18
19			11.42	28.97	7.04	8.95	4.07	2.36	2.99	1.11	1.81	0.33	19
20			12.02	31.85	7.42	9.84	4.28	2.59	3.15	1.22	1.91	0.36	20
22			13.22	38.00	8.16	11.74	4.71	3.09	3.46	1.46	2.10	0.43	22
24			14.42	44.65	8.90	13.79	5.14	3.63	3.78	1.72	2.29	0.51	24
25			15.02	48.15	9.27	14.87	5.36	3.92	3.94	1.85	2.39	0.55	25
26			15.62	51.78	9.64	16.00	5.57	4.21	4.09	1.99	2.48	0.59	26
28			16.83	59.40	10.38	18.35	6.00	4.83	4.41	2.28	2.67	0.68	28
30			18.03	67.50	11.12	20.85	6.43	5.49	4.72	2.59	2.86	0.77	30
32			19.23	76.06	11.86	23.50	6.86	6.19	5.04	2.92	3.06	0.87	32
34					12.61	26.29	7.28	6.92	5.35	3.27	3.25	0.97	34
35					12.98	27.74	7.50	7.30	5.51	3.45	3.34	1.02	35
36					13.35	29.22	7.71	7.69	5.67	3.63	3.44	1.08	36
38					14.09	32.30	8.14	8.50	5.98	4.02	3.63	1.19	38
40					14.83	35.52	8.57	9.35	6.30	4.42	3.82	1.31	40
42					15.57	38.88	9.00	10.24	6.61	4.83	4.01	1.43	42
44					16.31	42.38	9.43	11.16	6.93	5.27	4.20	1.56	44
45					16.68	44.18	9.64	11.63	7.08	5.49	4.30	1.63	45
46					17.06	46.01	9.86	12.12	7.24	5.72	4.39	1.70	46
48					17.80	49.79	10.28	13.11	7.56	6.19	4.58	1.84	48
50					18.54	53.70	10.71	14.14	7.87	6.68	4.77	1.98	50
55							11.78	16.87	8.66	7.97	5.25	2.36	55
60							12.85	19.82	9.44	9.36	5.73	2.77	60
65							13.93	22.98	10.23	10.86	6.21	3.22	65
70							15.00	26.36	11.02	12.45	6.68	3.69	70
75							16.07	29.96	11.81	14.15	7.16	4.19	75
80							17.14	33.76	12.59	15.95	7.64	4.73	80
85							18.21	37.77	13.38	17.84	8.12	5.29	85
90							19.28	41.99	14.17	19.83	8.59	5.88	90
95									14.95	21.92	9.07	6.50	95
100									15.74	24.11	9.55	7.15	100
110									17.31	28.76	10.50	8.53	110
120									18.89	33.79	11.46	10.02	120
130											12.41	11.62	130
140											13.37	13.33	140
150											14.32	15.14	150
160											15.28	17.07	160
170											16.23	19.09	170
180											17.19	21.23	180
190											18.14	23.46	190
200											19.10	25.80	200

Shaded area represents velocities over 5 FPS.
Use with caution where water hammer is a concern.

Index

C

C factor, 18, 21
C=150, 21
Class-rated pipes, 21

D

Dynamic pressure, 12, 16, 25, 41
Dynamic pressure losses, 40
Dynamic pressure losses in pipe, 24

E

Elevation change, 11, 24

F

Factors affecting flow, 27
Feet of head, 7, 9
Flow, 31, 32, 33, 41
Friction loss charts, 46
Friction loss in pipe, 16, 41

H

Hazen-Williams formula, 19
Hydraulics, 6

I

inside diameter (i.d.), 16, 17, 21
IPS (Iron Pipe Size), 20

L

Length, 16, 19

N

Nominal pipe size, 21
Number of outlets, 34

O

outside diameter (o.d.), 21

P

Point of connection, 44
Pressure, 28
Pressure loss, 37, 39
Pressure loss charts, 20
Pressure loss in fittings, 44
Pressure losses, 34
psi, 7, 9, 34
psi loss, 21

Q

Quantity (gpm), 27

R

Roughness, 16, 18
Roughness factor, 19

S

Sample problems, 14, 23, 25, 40
Schedule-rated pipes, 21
SDR (Standard dimension ratio), 21
Static pressure, 12, 14, 41
Summary, 44

T

Technical charts, 23

V

Velocity, 16, 17, 21, 27
Velocity Head, 41

NOTES

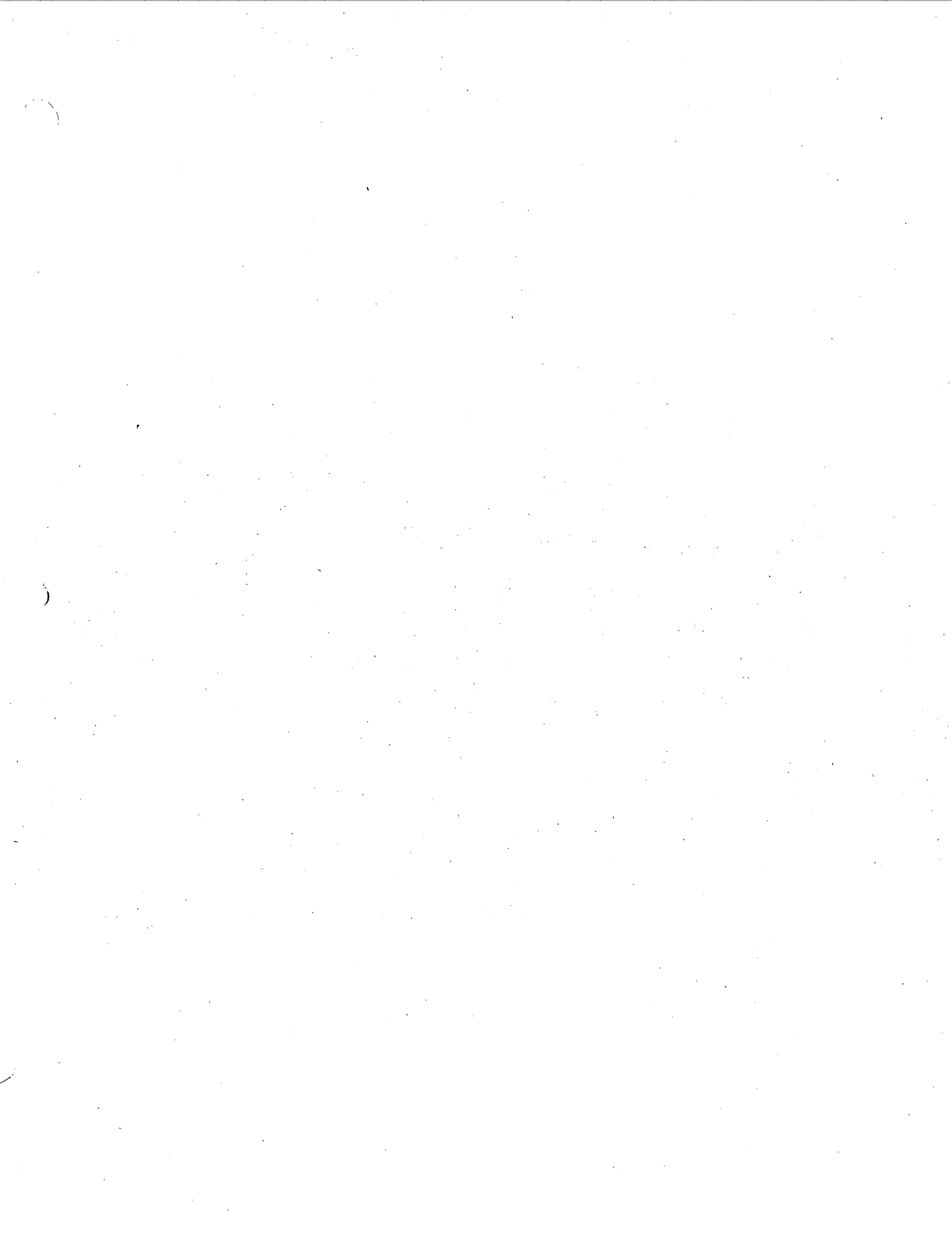

*Authored by: Bradford R. Monroe, Program Coordinator for
Ornamental Horticulture and Irrigation Technology at
Cuyamaca College in El Cajon, California.*